



OFFICE OF STATEWIDE HEALTH PLANNING AND DEVELOPMENT
FACILITIES DEVELOPMENT DIVISION

APPLICATION FOR OSHPD PREAPPROVAL
OF MANUFACTURER'S CERTIFICATION (OPM)

OFFICE USE ONLY
APPLICATION #: OPM-0474-13

OSHPD Preapproval of Manufacturer's Certification (OPM)

Type: [X] New [ ] Renewal [ ] Update to Pre-CBC 2013 OPA Number:

Manufacturer Information

Manufacturer: MIDMARK CORPORATION
Manufacturer's Technical Representative: Renee Browder
Mailing Address: 60 Vista Drive, Versailles, OH 45380
Telephone: (937) 526 - 8705 Email: RBrowder@midmark.com

Product Information

Product Name: Midmark Corporation Dental Phoenix CS
Product Type: Dental Cabinet
Product Model Number: 027-2096-00
General Description: Floor-supported cabinet

Applicant Information

Applicant Company Name: ZFA Structural Engineers
Contact Person: Ryan Bogart
Mailing Address: 601 Montgomery Street, Suite 1450, San Francisco, CA, 94111
Telephone: 415-243-4091 x202 Email: ryanb@zfa.com

I hereby agree to reimburse the Office of Statewide Health Planning and Development review fees in accordance with the California Administrative Code, 2016.

Signature of Applicant: [Handwritten Signature] Date: 3/12/2018
Title: Senior Associate Company Name: ZFA Structural Engineers

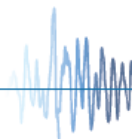



**OFFICE OF STATEWIDE HEALTH PLANNING AND DEVELOPMENT  
FACILITIES DEVELOPMENT DIVISION**

**Registered Design Professional Preparing Engineering Recommendations**

Company Name: ZFA Structural Engineers

Name: Mark Moore California License Number: S4443

Mailing Address: 601 Montgomery Street, Suite 1450, San Francisco, CA, 94111

Telephone: 415-243-4091 x201 Email: markm@zfa.com

**OSHPD Special Seismic Certification Preapproval (OSP)**

- Special Seismic Certification is preapproved under OSP-  
(Separate application for OSP is required)
- Special Seismic Certification is not preapproved

**Certification Method(s)**

- Testing in accordance with:  ICC-ES AC156  FM 1950-16
- Other\* (Please Specify): \_\_\_\_\_

\*Use of criteria other than those adopted by the California Building Standards Code, 2016 (CBSC 2016) for component supports and attachments are not permitted. For distribution system, interior partition wall, and suspended ceiling seismic bracings, test criteria other than those adopted in the CBSC 2016 may be used when approved by OSHPD prior to testing.

- Analysis
- Experience Data
- Combination of Testing, Analysis, and/or Experience Data (Please Specify): \_\_\_\_\_

**List of Attachments Supporting the Manufacturer's Certification**

- Test Report  Drawings  Calculations  Manufacturer's Catalog
- Other(s) (Please Specify): \_\_\_\_\_

**OFFICE USE ONLY – OSHPD APPROVAL VALID FOR CBC 2016 & ALL PRE-2016 CODE BASED PROJECTS**

Signature: Sonia Eliseo Date: 8/9/2019

Print Name: Sonia Eliseo

Title: Senior Structural Engineer

Condition of Approval (if applicable): \_\_\_\_\_

"Access to Safe, Quality Healthcare Environments that Meet California's

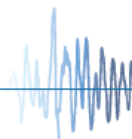

EQUIPMENT MANUFACTURER:  
MIDMARK CORPORATION

OPM-0474-13

**ZFA STRUCTURAL ENGINEERS**  
601 montgomery street | suite 1450 | san francisco ca 94111 | 415.243.4091 | zfa.com

DATE: 03/07/2018  
JOB NO.: 18005

SHEET  
**1**  
OF 6

EQUIPMENT TYPE:  
UNIT# 027-2096-00 (PHOENIX CS)

TABLE OF CONTENTS

GENERAL NOTES .....	1-2
ATTACHMENT DETAILS - CONCRETE SLAB .....	3
ATTACHMENT DETAILS - CONCRETE FILLED METAL DECK .....	4
ANCHOR PLACEMENT AND BASE MATERIAL OF UNIT .....	5
MIN METAL DECK AND STRUT REQUIREMENTS .....	6

GENERAL NOTES

1. THIS OSHPD PREAPPROVAL OF MANUFACTURER'S CERTIFICATION (OPM) IS BASED ON THE CBC 2016. THE DEMAND (DESIGN FORCES) FOR USE WITH THIS OPM SHALL BE BASED ON THE CBC 2016.
2. THE DOCUMENT MAY ONLY BE USED WITH THE EXPRESS WRITTEN CONSENT OF THE MANUFACTURER LISTED ABOVE FOR A SPECIFIC PROJECT SITE AND INSTALLATION LOCATION. THE DOCUMENT IS INVALID WITHOUT SUCH CONSENT.
3. FORCES PER ASCE 7-10 SECTION 13.3.1, EQUATIONS. 13.3-1, 13.3-2 & 13.3-3, WHERE:  
 $S_{DS} = 2.20$ ,  $a_p = 1.0$ ,  $I_p = 1.5$  &  $R_p = 2.5$ ,  $z/h \leq 1.0$ , AT ANY LOCATION IN BUILDING.  
 $z/h = 0$ , AT OR BELOW GRADE
4. THE DETAILS IN THIS PRE-APPROVAL MAY BE USED AT ANY LOCATION WHERE THE  $S_{DS}$  DOES NOT EXCEED 2.20.
5. ALL SEISMIC AND ANCHOR FORCES SHOWN IN THIS OPM ARE AT STRENGTH LEVEL AND MAY BE USED FOR STRENGTH LEVEL DESIGN.
6. THIS PRE-APPROVAL COVERS ONLY THE SUPPORTS AND ATTACHMENTS OF THE EQUIPMENT TO THE STRUCTURE.

RESPONSIBILITIES OF THE STRUCTURAL ENGINEER OF RECORD (SEOR)

7. VERIFY THAT THE INSTALLATION IS IN CONFORMANCE WITH THE 2016 CBC AND WITH THE DETAILS SHOWN IN THIS PRE-APPROVAL DOCUMENT.
8. VERIFY THAT THE ACTUAL EQUIPMENT WEIGHT, CENTER OF GRAVITY (CG) LOCATION, AND MATERIAL AND GAGE OF THE UNIT WHERE ATTACHMENT OCCURS ARE IN AGREEMENT WITH THIS PRE-APPROVAL DOCUMENT.
9. VERIFY THAT THE ATTACHMENTS MEET THE MINIMUM SPACING AND EDGE DISTANCE REQUIREMENTS DEFINED IN THIS PRE-APPROVAL DOCUMENT AND ANY CORRESPONDING ICC-ES EVALUATION REPORT.
10. VERIFY THE ADEQUACY OF THE STRUCTURES SUPPORTING THE EQUIPMENT (SUCH AS WALLS AND FLOORS) FOR LOADS IMPOSED BY THE EQUIPMENT, AS WELL AS ALL OTHER LOADS.
11. PROVIDE ANY SUPPORTING STRUCTURE REQUIRED TO SUPPORT WEIGHTS AND FORCES SHOWN, IN ADDITION TO ALL OTHER LOADS.
12. VERIFY THAT THE COMBINATION OF  $S_{DS}$  &  $z/h$  RESULT IN SEISMIC FORCES THAT ARE NOT GREATER THAN THE VALUES IN THIS PREAPPROVAL DOCUMENT.

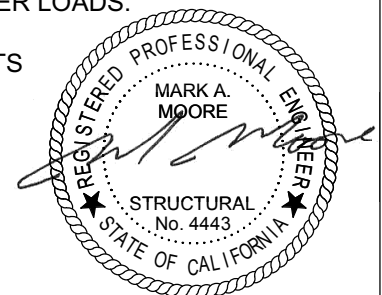

EQUIPMENT MANUFACTURER:  
MIDMARK CORPORATION

OPM-0474-13

**ZFA STRUCTURAL ENGINEERS**  
601 montgomery street | suite 1450 | san francisco ca 94111 | 415.243.4091 | zfa.com

DATE: 03/07/2018  
JOB NO.: 18005

SHEET  
**2**  
OF 6

EQUIPMENT TYPE:  
UNIT# 027-2096-00 (PHOENIX CS)

SHEET METAL SCREW NOTES

- 1. SHEET METAL SCREWS (SMS) SHALL CONFORM TO ICC-ES ESR-1976 OR ICC-ES ESR-2196. MINIMUM EDGE DISTANCE, SPACING AND EMBEDMENT INTO LIGHT GAUGE STEEL PER ICC REPORT.

POST-INSTALLED ANCHOR NOTES

- 2. POST-INSTALLED ANCHORS FOR ATTACHING EQUIPMENT TO SUPPORT STRUCTURE SHALL BE HILTI KWIK BOLT TZ ANCHORS. SEE INFORMATION BELOW ALONG WITH THE CORRESPONDING ICC-ES EVALUATION REPORT FOR INSTALLATION INSTRUCTIONS.

Anchor Diameter	Anchor Type	ICC Report No.	Concrete Type	Min f'c (psi)	Min. Conc. Thickness	Min. Embed (h <sub>eff</sub> )	Min. Spacing	Min. Edge Dist	Installation Torque
5/8"	Hilti KB-TZ	ESR-1917	Normal Weight.	3000	6"	4"	8"	36"	60 ft-lb

TESTING OF POST-INSTALLED ANCHORS

- 3. TESTING OF EXPANSION ANCHORS SHALL BE PER 2016 CBC, 1910A.5.2 AND 1910A.5.4: TEST SHALL BE DONE IN THE PRESENCE OF A SPECIAL INSPECTOR AND A REPORT OF THE TEST RESULTS SHALL BE SUBMITTED TO OSHPD.

- A. AFTER AT LEAST 24 HOURS HAVE ELAPSED SINCE INSTALLATION, TORQUE OR DIRECT PULL TEST 50% OF THE ANCHORS OR ALTERNATE BOLTS IN AN ANCHOR GROUP.

Anchor Diameter	Anchor Type	Torque Test	Tension/Direct Pull Test
5/8"	Hilti KB-TZ	60 ft-lb	4540 lb

- B. ACCEPTANCE CRITERIA:

TORQUE TEST: FOR WEDGE TYPE ANCHORS, THE APPLICABLE TORQUE MUST BE ACHIEVED WITHIN A 1/2 TURN OF THE NUT

TENSION TEST: ANCHORS SHOULD HAVE NO OBSERVABLE MOVEMENT AT THE TEST LOAD. A PRACTICAL WAY TO DETERMINE IF ANY MOVEMENT HAS OCCURED IS TO CHECK IF THE WASHER HAS BECOME LOOSE.

- C. IF ANY ANCHOR FAILS, TEST ALL ANCHORS.

- 4. AVOID DAMAGING EXISTING STEEL REINFORCEMENT IN CONCRETE WHEN INSTALLING EXPANSION ANCHORS.

- 5. PROVIDE FOR FULL THREAD ENGAGEMENT OF NUT AND WASHER.

BOLTS THROUGH CONCRETE ON METAL DECK

- 6. BOLTS SHALL BE TORQUED BY A 3/4 TURN OF THE NUT AFTER A SNUG TIGHT CONDITION IS ACHIEVED. SNUG TIGHT CONDITION IS DEFINED AS THE TIGHTNESS REQUIRED TO BRING CONNECTED ELEMENTS INTO FIRM CONTACT.

- 7. HOLES DRILLED IN CONCRETE SHALL BE 1/16" LARGER THAN THE BOLT SIZE.

- 8. THROUGH-BOLTS INTO CONCRETE SHALL RECEIVE SPECIAL INSPECTION AND TESTING (THROUGH BOLTS WITH STEEL TO STEEL CONNECTION IN TENSION DO NOT REQUIRE TENSION TESTING) IN ACCORDANCE WITH REQUIREMENTS FOR POST-INSTALLED ANCHORS.



EQUIPMENT MANUFACTURER:  
MIDMARK CORPORATION

OPM-0474-13

**ZFA STRUCTURAL ENGINEERS**  
601 montgomery street | suite 1450 | san francisco ca 94111 | 415.243.4091 | zfa.com

DATE: 03/07/2018  
JOB NO.: 18005

SHEET  
**3**  
OF 6

EQUIPMENT TYPE:  
UNIT# 027-2096-00 (PHOENIX CS)

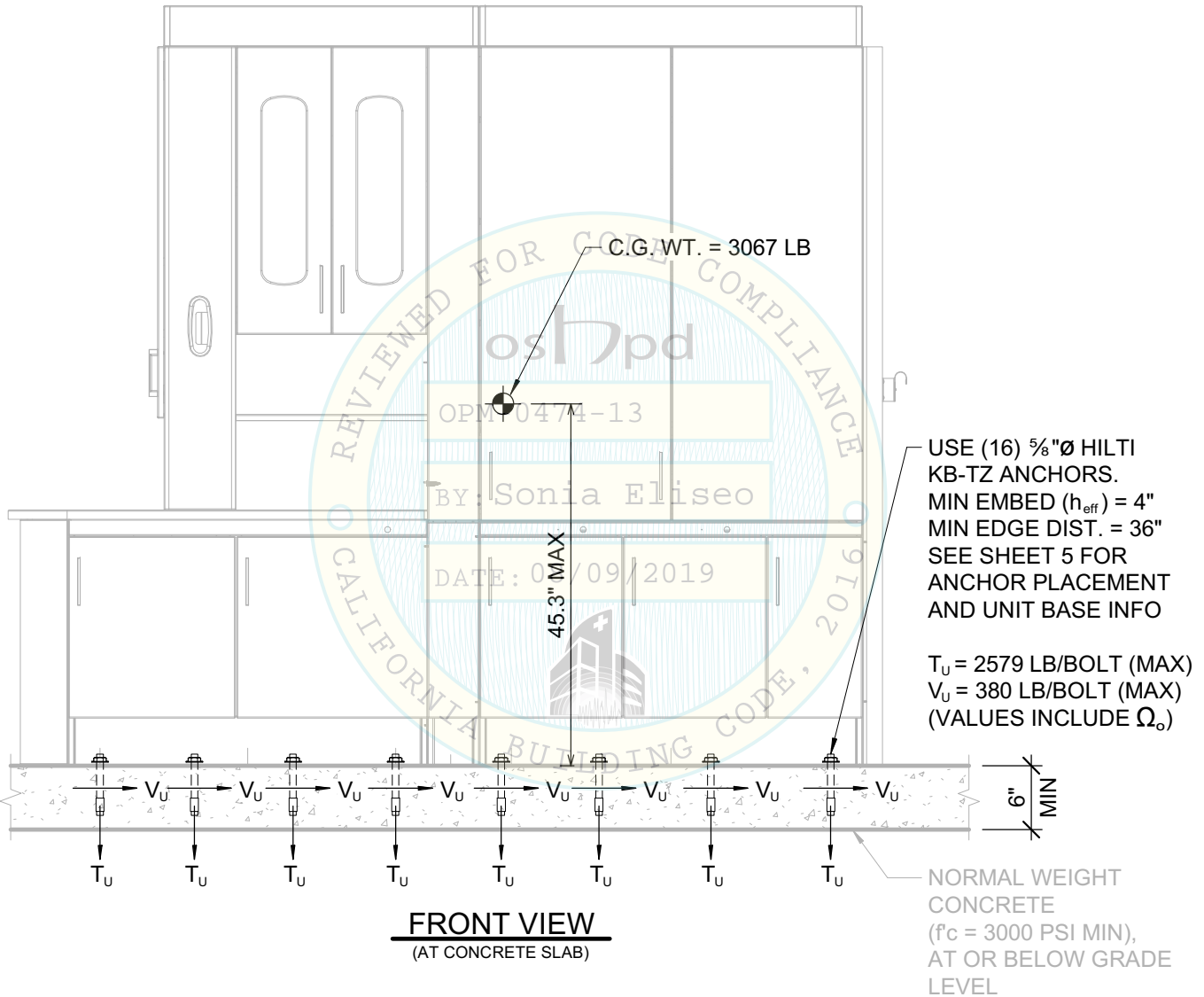

**NOTES**

- FORCES ARE DETERMINED PER CBC 2016 AND ASCE 7-10 WITH  $S_{DS} = 2.20$ ,  $a_p = 1.0$ ,  $I_p = 1.5$ ,  $R_p = 2.5$ , &  $z/h = 0$ , AT OR BELOW GRADE.  
HORIZONTAL SEISMIC FORCE ( $E_h$ ) = 0.990  $W_p$  (UNFACTORED)  
VERTICAL SEISMIC FORCE ( $E_v$ ) = 0.440  $W_p$  (UNFACTORED)
- OVERSTRENGTH FACTOR,  $\Omega_o = 2.0$ , SHALL BE APPLIED TO CONCRETE ANCHOR FORCES PER CBC 1616A.1.23
- CENTER OF GRAVITY (CG) AND EQUIPMENT WEIGHT ARE MAXIMUM VALUES. THIS PREAPPROVAL ENCOMPASSES ALL WEIGHTS UP TO THE MAXIMUM SHOWN
- STRUCTURAL ENGINEER OF RECORD SHALL PROVIDE SUPPORT STRUCTURE DESIGNED TO SUPPORT WEIGHTS AND FORCES SHOWN, IN COMBINATION WITH ALL OTHER LOADS.
- SEE SHEET 1 AND 2 FOR GENERAL NOTES.



EQUIPMENT MANUFACTURER:  
MIDMARK CORPORATION

OPM-0474-13

**ZFA STRUCTURAL ENGINEERS**  
601 montgomery street | suite 1450 | san francisco ca 94111 | 415.243.4091 | zfa.com

DATE: 03/07/2018  
JOB NO.: 18005

SHEET  
**4**  
OF 6

EQUIPMENT TYPE:  
UNIT# 027-2096-00 (PHOENIX CS)

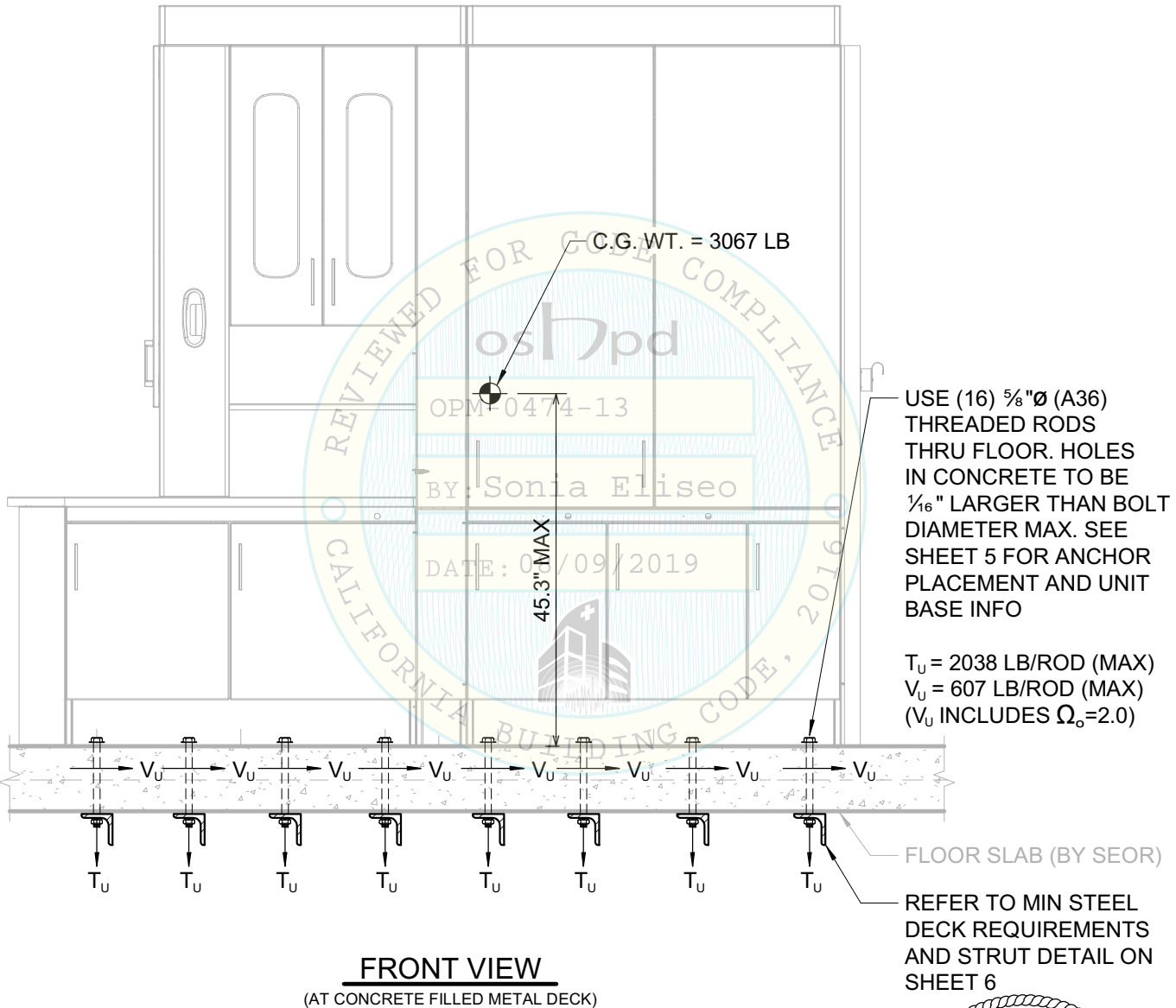

USE (16) 5/8"Ø (A36)  
THREADED RODS  
THRU FLOOR. HOLES  
IN CONCRETE TO BE  
1/16" LARGER THAN BOLT  
DIAMETER MAX. SEE  
SHEET 5 FOR ANCHOR  
PLACEMENT AND UNIT  
BASE INFO

$T_u = 2038$  LB/ROD (MAX)  
 $V_u = 607$  LB/ROD (MAX)  
( $V_u$  INCLUDES  $\Omega_o = 2.0$ )

FLOOR SLAB (BY SEOR)  
REFER TO MIN STEEL  
DECK REQUIREMENTS  
AND STRUT DETAIL ON  
SHEET 6

**NOTES**

- FORCES ARE DETERMINED PER CBC 2016 AND ASCE 7-10, WITH  $S_{DS} = 2.20$ ,  $a_p = 1.0$ ,  $I_p = 1.5$ ,  $R_p = 2.5$ , &  $z/h \leq 1$ , AT ANY LOCATION IN BUILDING.  
HORIZONTAL SEISMIC FORCE ( $E_h$ ) = 1.584  $W_p$  (UNFACTORED)  
VERTICAL SEISMIC FORCE ( $E_v$ ) = 0.440  $W_p$  (UNFACTORED)
- CENTER OF GRAVITY (CG) AND EQUIPMENT WEIGHT ARE MAXIMUM VALUES.  
THIS PREAPPROVAL ENCOMPASSES ALL WEIGHTS UP TO THE MAXIMUM SHOWN
- STRUCTURAL ENGINEER OF RECORD SHALL PROVIDE SUPPORT STRUCTURE DESIGNED TO SUPPORT WEIGHTS AND FORCES SHOWN, IN COMBINATION WITH ALL OTHER LOADS.
- SEE SHEET 1 AND 2 FOR GENERAL NOTES.

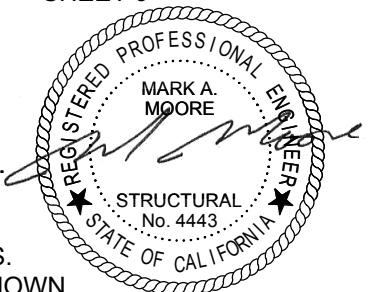

EQUIPMENT MANUFACTURER:  
MIDMARK CORPORATION

OPM-0474-13

**ZFA STRUCTURAL ENGINEERS**  
601 montgomery street | suite 1450 | san francisco ca 94111 | 415.243.4091 | zfa.com

DATE: 03/07/2018  
JOB NO.: 18005

SHEET  
**5**  
OF 6

EQUIPMENT TYPE:  
UNIT# 027-2096-00 (PHOENIX CS)

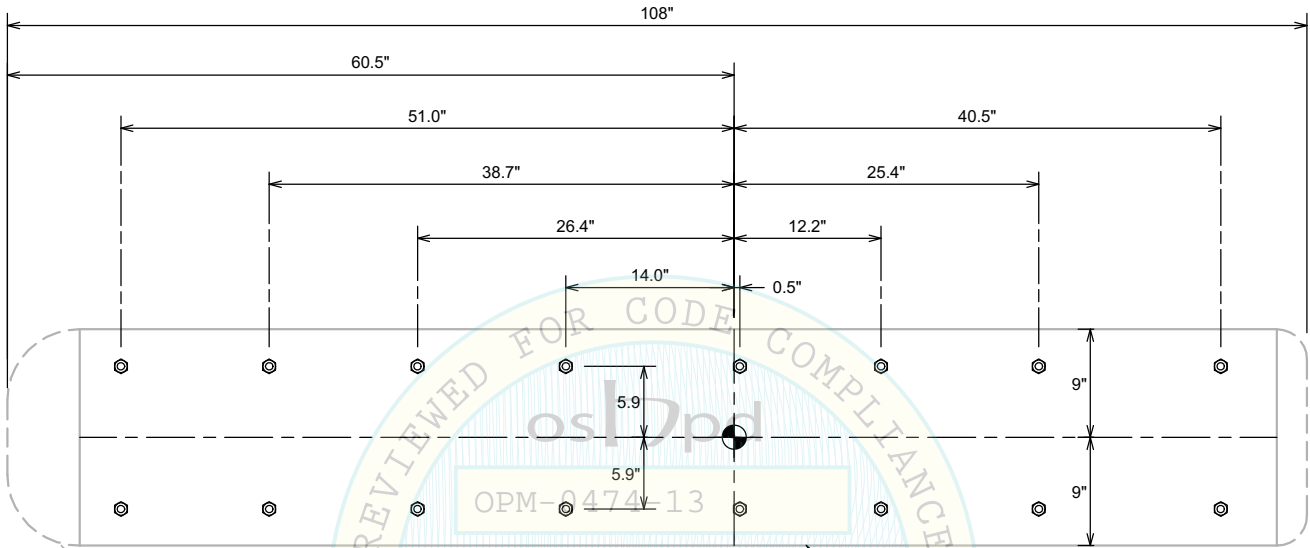

EDGE OF EQUIPMENT

**PLAN AT BASE**

SOLID LINE INDICATES PERIMETER OF BOTTOM FLANGE

**BOTTOM FLANGE OF CABINET**  
MIN THICKNESS = 18GA  
MINIMUM Fy = 20 KSI  
(ASTM A1008 CS TYPE B)

**MOUNTING RAIL**  
MIN THICKNESS = 12GA  
MINIMUM Fy = 20 KSI  
(ASTM A1008 CS TYPE B)

12GA BENT PLATE MIN Fy = 20 KSI  
(ASTM A1008 CS TYPE B)  
CENTER AT EACH MOUNTING  
RAIL W/ (3) #14 SMS

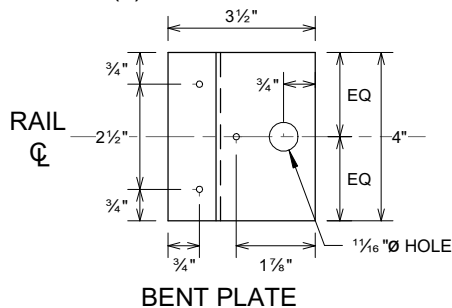

**BENT PLATE**

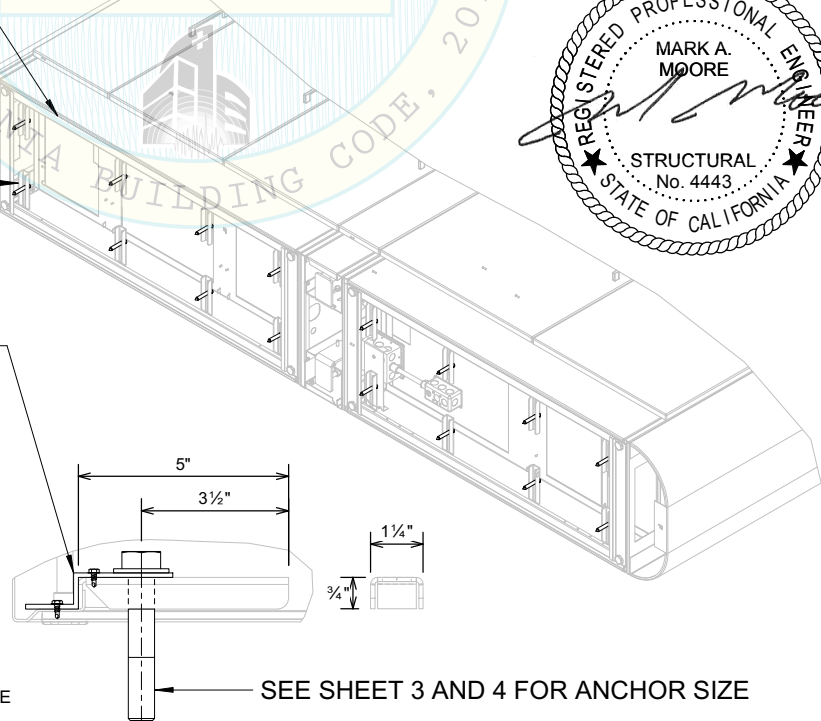

SEE SHEET 3 AND 4 FOR ANCHOR SIZE

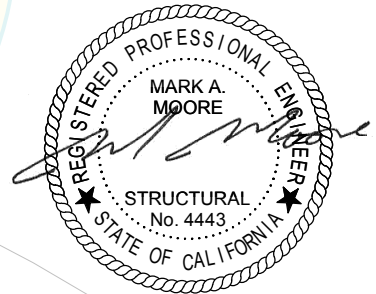

**UNIT BASE ISOMETRIC VIEW AND  
MOUNTING RAIL DIMENSIONS**

EQUIPMENT MANUFACTURER:  
MIDMARK CORPORATION

OPM-0474-13

**ZFA STRUCTURAL ENGINEERS**  
601 montgomery street | suite 1450 | san francisco ca 94111 | 415.243.4091 | zfa.com

DATE: 03/07/2018  
JOB NO.: 18005

SHEET  
**6**  
OF 6

EQUIPMENT TYPE:  
UNIT# 027-2096-00 (PHOENIX CS)

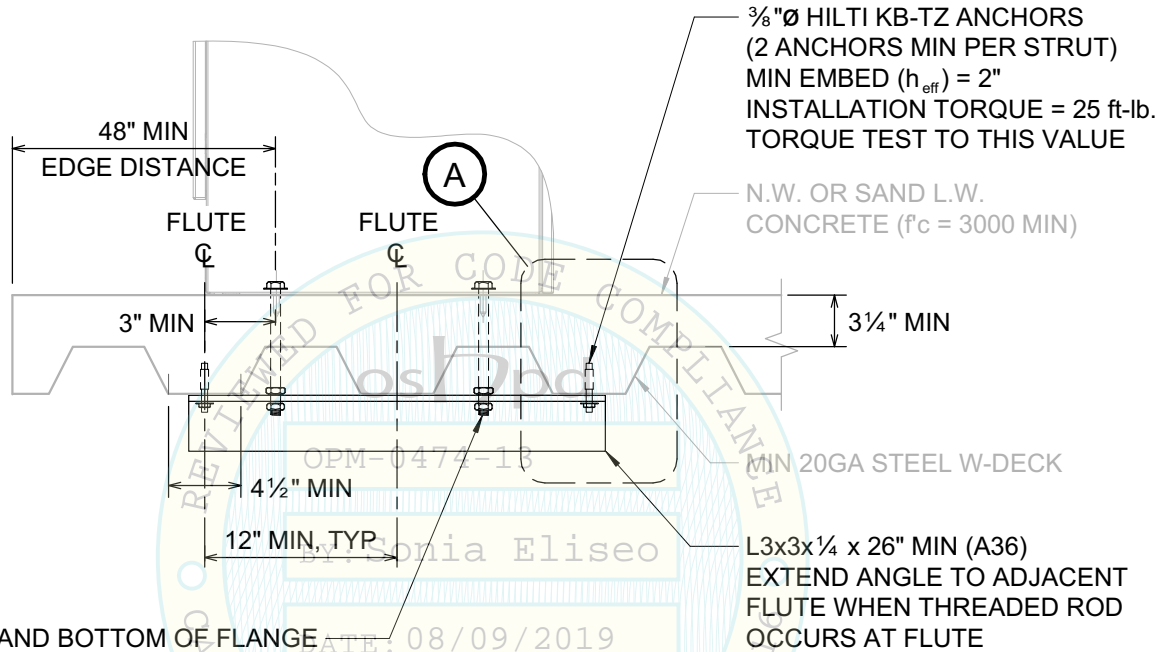

**MIN METAL DECK AND STRUT REQUIREMENTS**

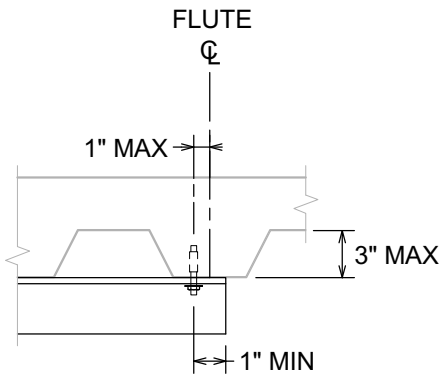

**A** FLUTE DETAIL

