



**Installation Instructions for
Single Bank of Ultrabases**

Introduction

Thank you very much for your investment in Mason kennels. We take great pride in providing our customers with the highest quality animal enclosures combined with an enjoyable ordering experience. The following instructions will assist you with proper assembly, cleaning, and maintenance of your Mason kennels. It is important to follow these guidelines in order to receive the best results and maximum life from your investment.

Assembly

The following pages will show you how to assemble your new Mason kennel. Since every order is custom built to your specifications, the instructions are designed to show the various methods used to assemble our kennels and some of the demonstrations may not apply to your order. Be sure to use the enclosed scale drawings at the end of this document of the provided hardware to ensure proper identification and usage.

Hardware

Depending on your Kennel project you may have some or all of the following hardware:

| Part # | Description | Part # | Description |
|---------------|---|---------------|--|
| 356 | 5/16" x 1-1/2" galv. carriage bolt(s) | 1468 | Square to round clamp(s) |
| 357 | 5/16" x 1-3/4" galv. carriage bolt(s) | 330 | Panel clamp(s) |
| 423 | 5/16"-18 nut(s) | 328 | Triple clamp(s) |
| 891 | #12 x 1" hex head sheet metal screw(s) | 6724 | Special pulleys (w/Kennel Door option) |
| 422 | 1/4" -20 hex nut(s) | | Tie plate(s) 1-1/2" x length of panel |
| 366 | 1/4"-20 X 1" hex head bolt(s) | 1474 | 1/4" x 1-1/4" rawl spike(s) (anchored systems only) |
| 369 | 1/4"-20 X 1-3/4" hex head bolt(s) | 2134 | Leg leveler Bolt(s) 1/2"-13 x 4" |
| 2449 | Sealant | 428 | 1/2 - 13 nut(s) |
| 2222 | #10 x 5/8" TEK hex washer head sheet metal screw(s) | 3120 | Triple clamp(s) – 1" (w/stainless steel gate option) |
| 369 | 1/4"-20 x 1-1/2" hex head bolt(s) (w/stainless steel gate option) | 1955 | 5/16" x 1-1/2" SS carriage bolt(s) |
| 368 | 1/4-20 x 1-1/4" hex head bolts | 1771 | 5/16" x 1-3/4" SS carriage bolt(s) |
| 3118 | Single clamp(s) – 1" (w/stainless steel gate option) | 424 | 5/16" – 18 SS hex nut |
| 8052 | Leg Assembly | 3119 | Double clamp(s) – 1" (w/stainless steel gate option) |
| 1200 | 2" x 2" Aluminum Angle | 421 | 1/4" -20 Nylok hex nut(s) |
| | | 1907 | 1/4"-20 x 1" Truss head screw(s) |

| | | | |
|------|--|------|--|
| 3808 | ¼" x 1 3/4" TAPCON | 2581 | #10 x 1 ½" TEK hex washer head sheet metal screw(s) |
| 1200 | 2" x 2" x 10 ½" Aluminum Angle | 8004 | 4" x 36" Trim Plate |
| 8005 | 4" x 48" Trim Plate | | 7 ½" Tall Front FRP Trim Panel |
| | 13" Tall Side FRP Trim Panel | 8082 | Double SS clamp(s) -1" (w/stainless steel gate option) |
| 8081 | Triple SS clamp(s) -1" (w/stainless steel gate option) | 8083 | Single SS clamp(s) -1" (w/stainless steel gate option) |

Installation

Required installation tooling:

- Level (4' preferred)
- 1 /2" combination wrench
- 7/16" combination wrench
- Hammer
- 3/4" combination wrench
- #2 Phillips bit (2-3)
- 5/16" socket and ratchet
- Permanent Marker
- 4 ½" Angle Grinder w/Abrasive Cutoff Wheel
- Hammer Drill
- 3/16" Masonry drill bit
- Caulk gun
- Drill (cordless)
- 5/32" drill bit
- Tape measure
- Chalk line
- Denatured alcohol
- Shop rags
- Impact Driver (cordless)
- 5/16" drill bit
- 5/16" Hex Driver Bit

Optional tools

- Vise grips – 8" locking C-clamps (3 pair recommended)
- WD40 or other thread lubricant

**Section A
Panel Identification**

Refer to the floor plan supplied.

Depending on the nature of your Kennel Project you will have either letter and or number designations on the tag(s) wired to the top of the panel as shown in Figure 1.

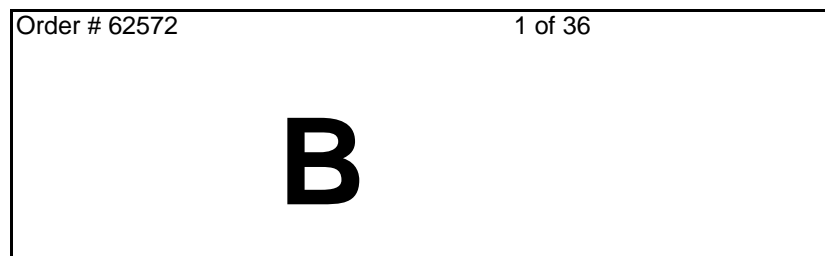

Figure 1.

On the floor plan each panel is marked with an alphanumeric designation that corresponds to the designation on the tag of the panel to be installed at a particular location.

Each connection point of the panels should be aligned as shown on the floor plan. It will make a difference as to how your runs go together if you do not align the panels properly, and in some cases they may not go together at all.

Section B Leveling leg assembly

1. Turn each unit until the bottom side is up (be sure to pad the floor with cardboard or other suitable material to protect the finish). Insert a leveling leg into each flange on the bottom of the base unit and tighten. See Figure 2.

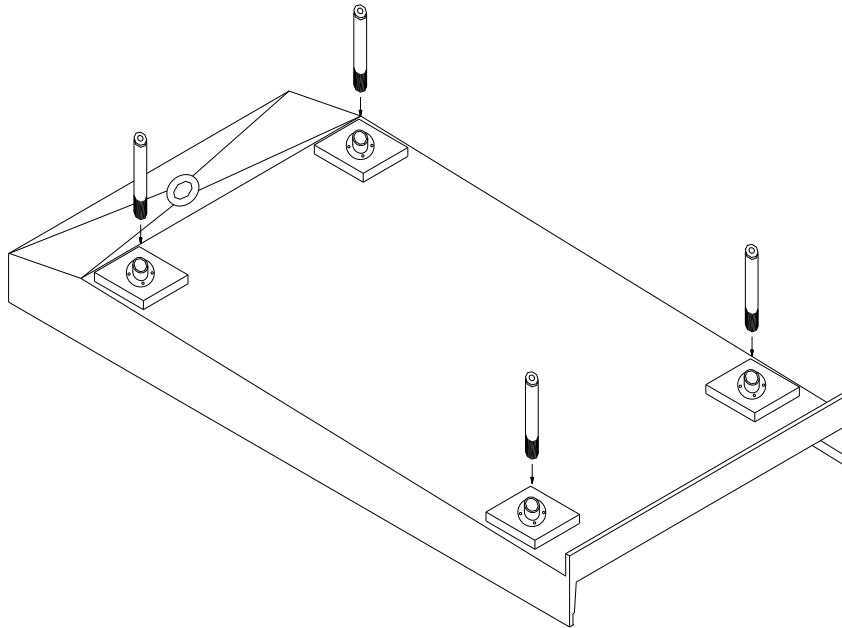

Figure 2.

2. Screw on a 1/2"-13 Nut onto all of the supplied leveling bolts. Insert the leveling bolts into the end of the leveling legs, screwing them in until they are all approx. halfway screwed in. see Figure 3.

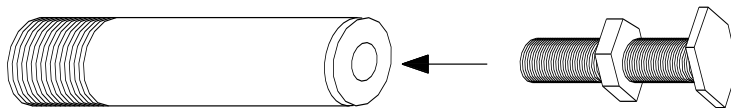

Figure 3.

Section C Drain Fitting assembly

1. Per the instructions in the package with the drain fitting, install and tighten.
2. **IMPORTANT: Every Ultrabase system's plumbing requirements are different depending on location, drainage requirements and drain locations. Once this system is installed it is**

difficult to access the Ultrabase drains for installing plumbing so you will want to plan your plumbing installation requirements before proceeding.

Section D Run Assembly

1. Refer to the floor plan and select a starting point for assembling the runs, which is best for your application. Once selected, begin placing the bases right side up in the proper location.

Section E Leveling the System

1. Level the system such that **ALL** the units are level along their top edges and are **ALL** at the same height on their edges, using the leveling screws installed in Step 1. See Figure 4.

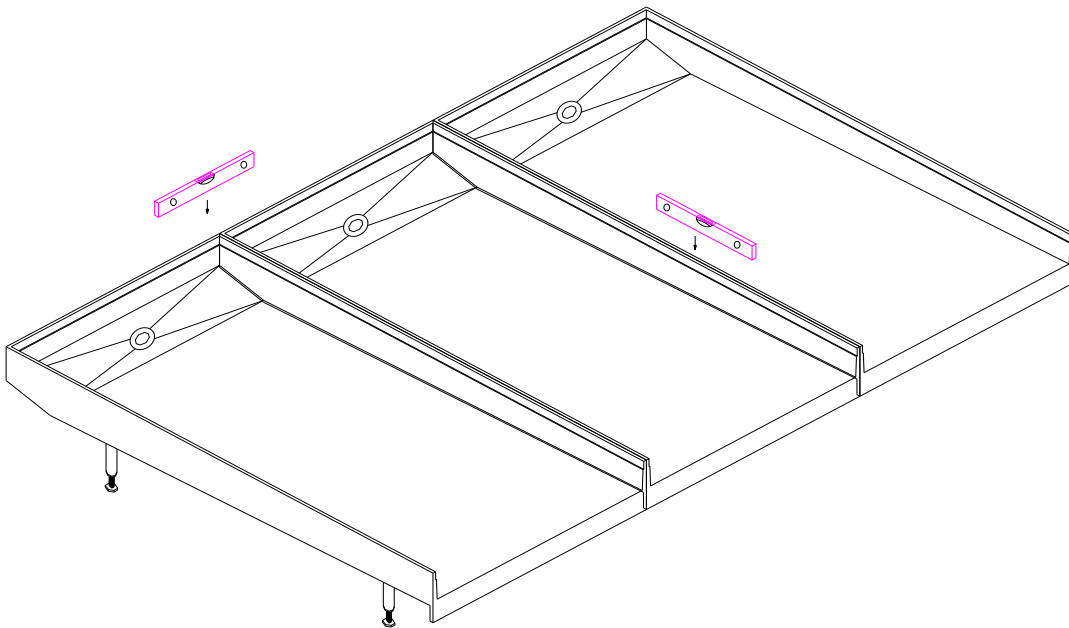

Figure 4.

2. Once all the units are at the same level, tighten the 1/2"-13 nuts to lock the leveling bolts in that position.

Section F Installation of Division and Back Panels

1. Beginning at one end of the system, place a division panel and a back panel onto the Ultrabase. It is important to have the division panel oriented with the narrower vertical extrusion toward the front of the Ultrabase. See Figure5.

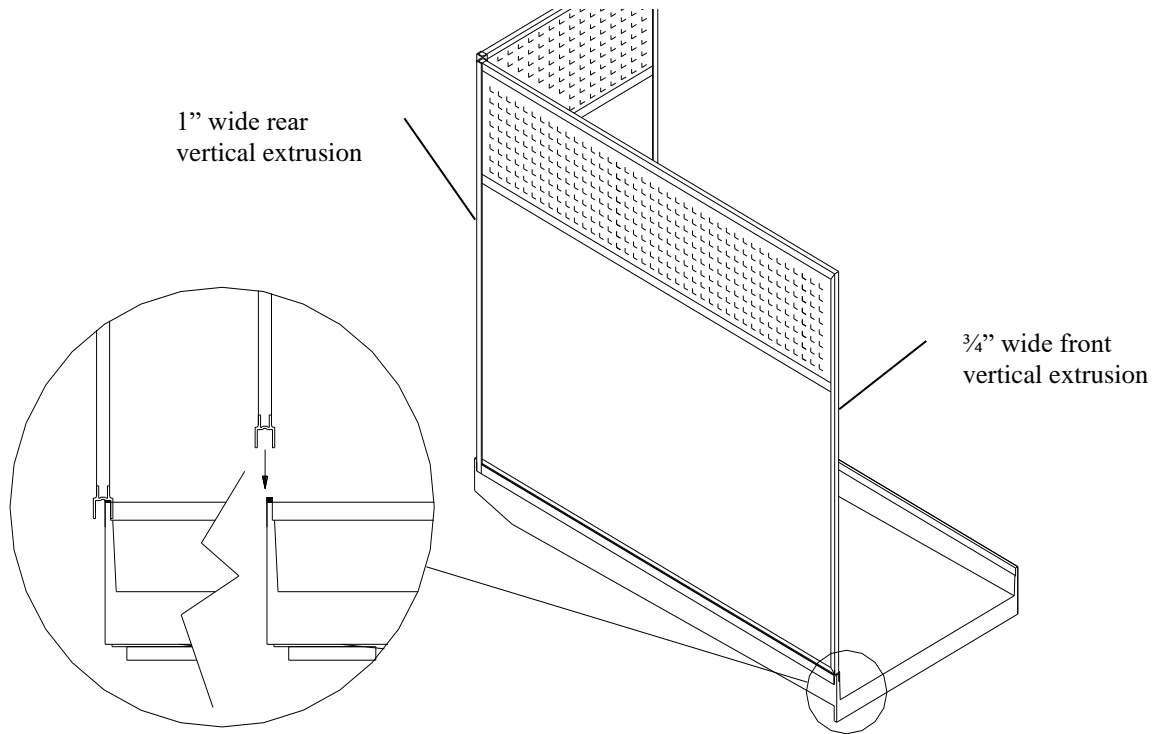

Figure 5.

2. Connect the first division panel to the first back panel using the 3/4" x 3/4" aluminum angle and #10 x 5/8" TEK Hex washer head sheet metal screws (#2222). These screws are self drilling and do not require pilot holes. Using vise grips, clamp the 3/4" x 3/4" angle in place. See Figure 6. **These may be preinstalled on the division panels from the factory in certain cases.**

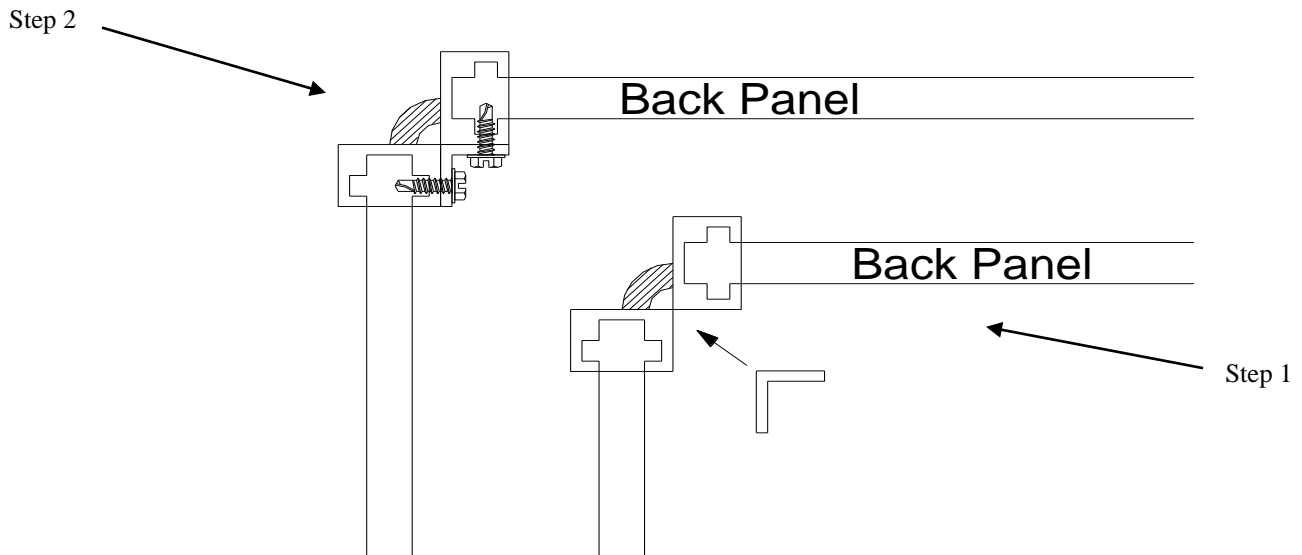

Figure 6

3. Place the 2nd division panel in place and connect to the 1st back panel using the 3/4" x 3/4" aluminum angle and #10 x 5/8" TEK hex washer head sheet metal screws (#2222). These screws

are self drilling and do not require pilot holes. **These may be preinstalled on the division panels from the factory in certain cases.**

4. Continue down the length of the run in the same manner. See Figure 7.

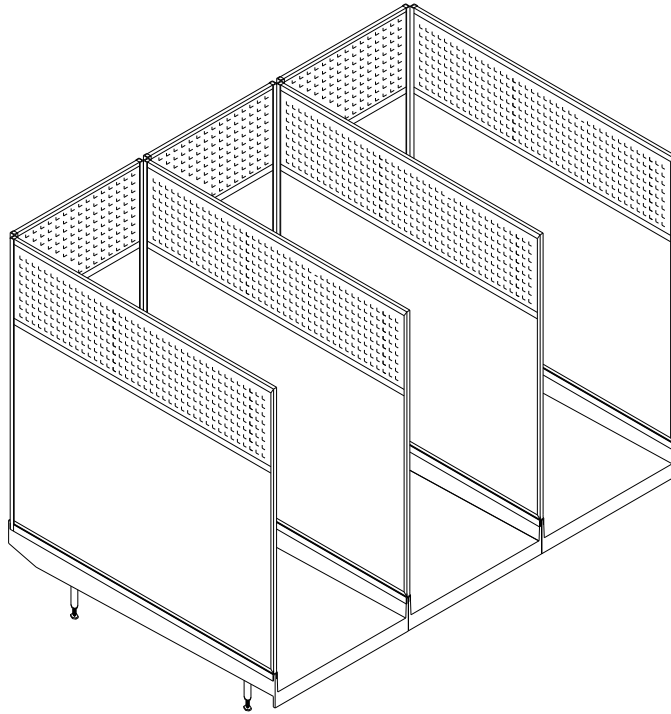

Figure 7.

5. Screw the division panels and back panels to the base units using #10 x 5/8" TEK hex washer head sheet metal screws (#2222). These screws are self drilling and do not require pilot holes. Use 2 screws per back panel and one screw per Division Panel. See Figure 8 for locations.

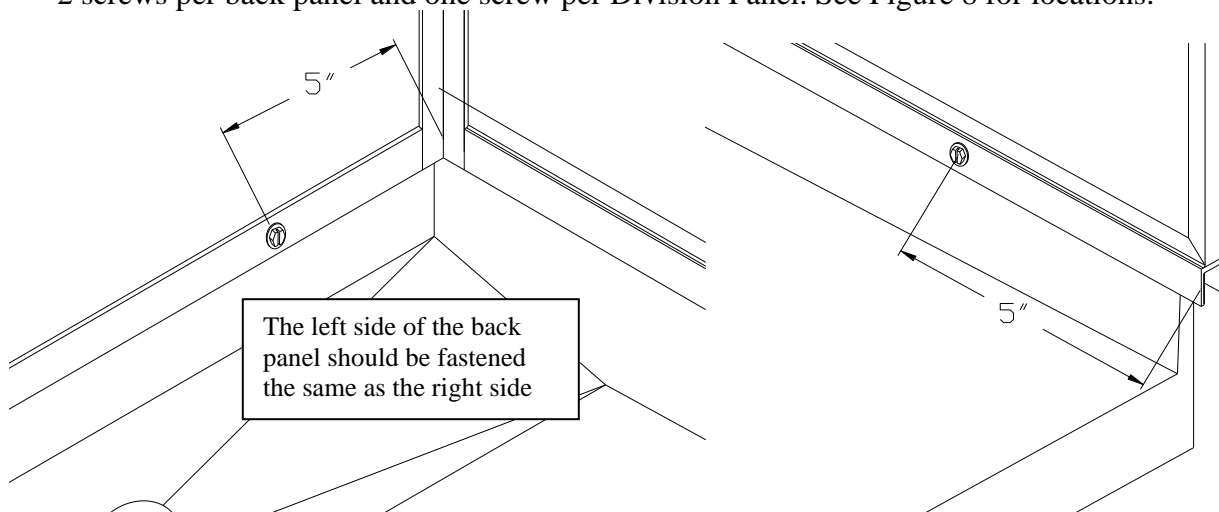

Figure 8

6. **NOTE:** if your system has chain link gates this step is not required. Insert plastic plugs as shown at the bottom front corner of each division panel. See Figure 9.

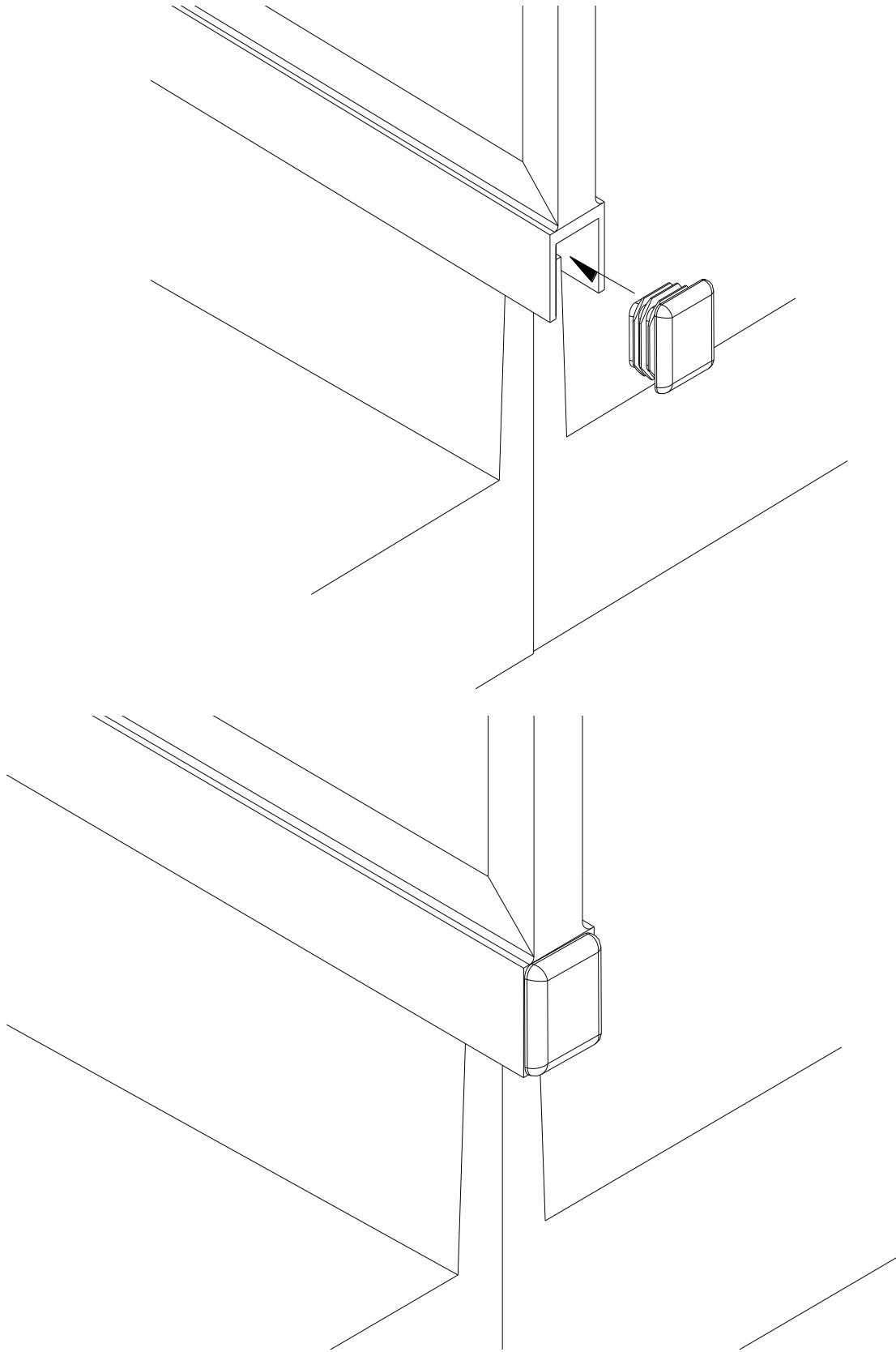

Figure 9

Section G Sealing

1. Seal the division panels and back panels to the base unit with silicone caulk along the joints where the bottoms of the panels meet the base unit. See Figure 10.

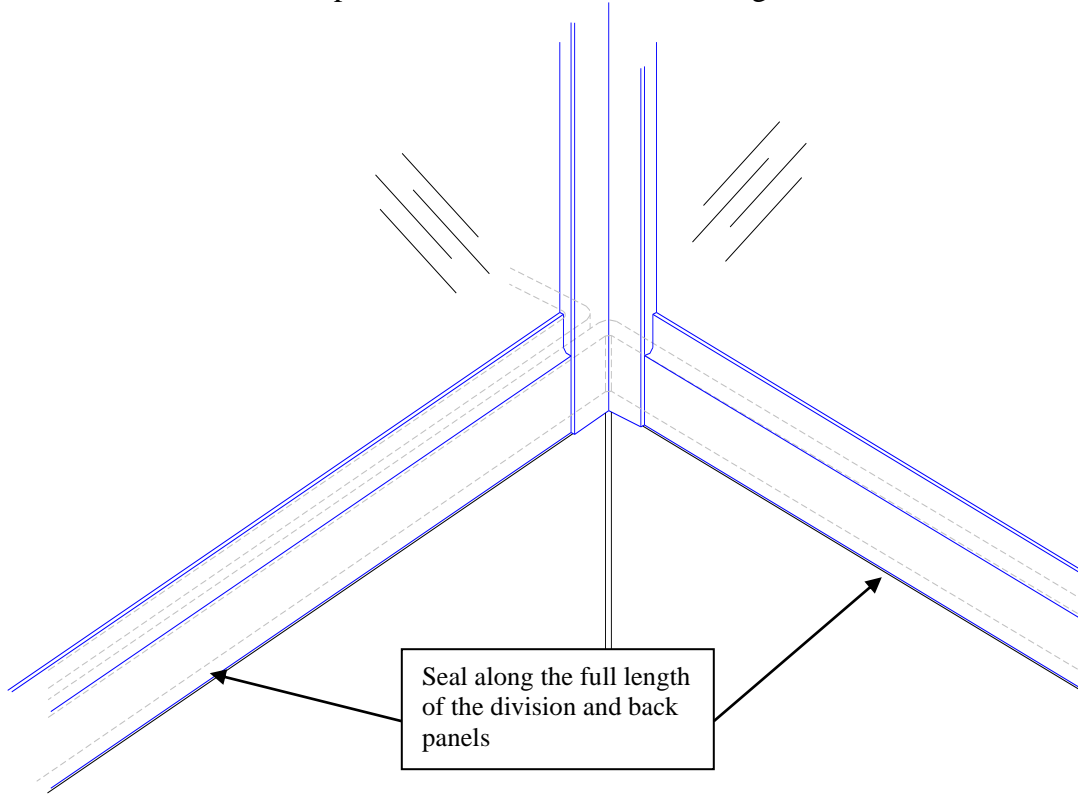

Figure 10.

2. Seal along both edges of the 3/4" x 3/4" angle used for the corner connections. See Figure 11.

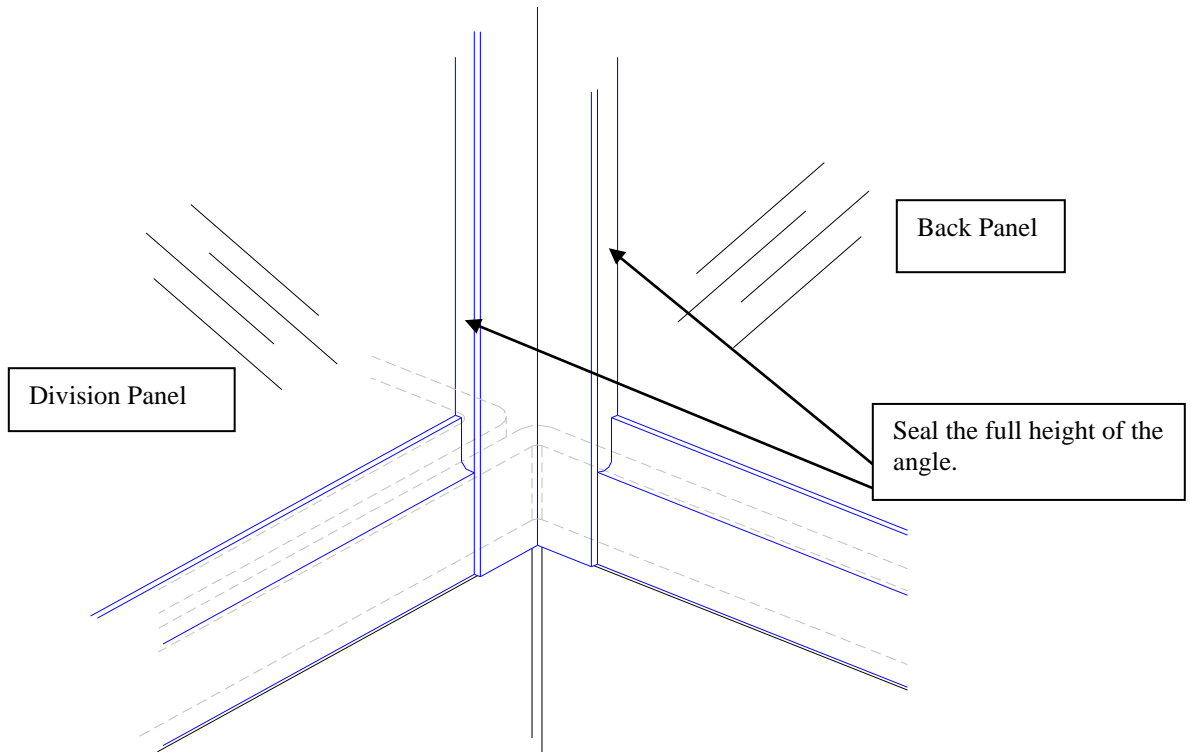

Figure 11.

3. From outside of the system, seal the joint where the back panels meet the division panels. See Figure 12.

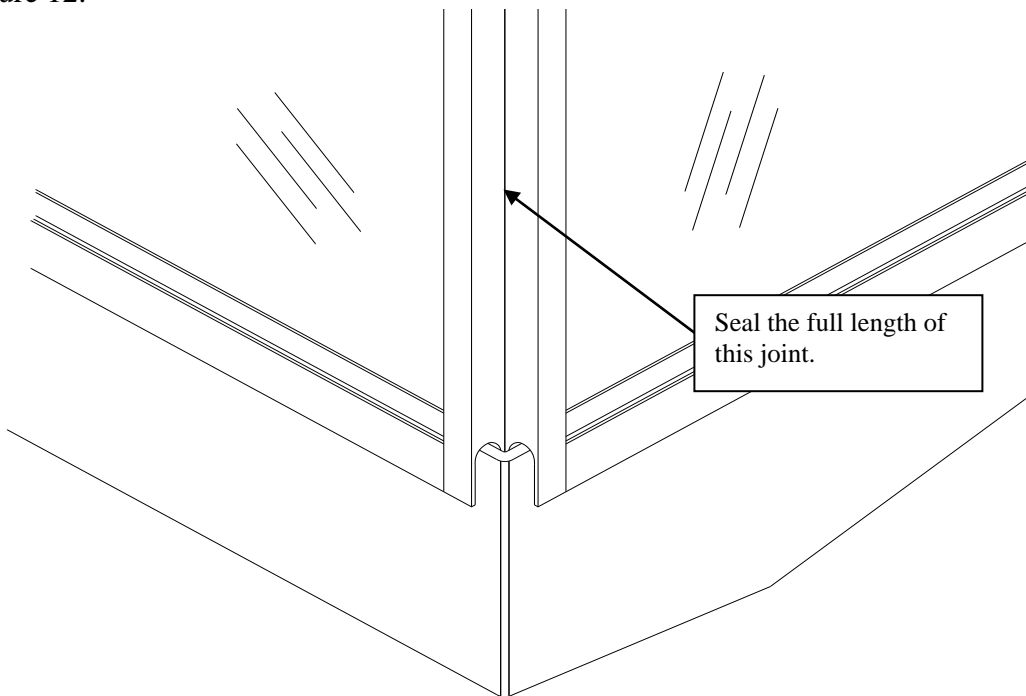

Figure 12.

**Section H
Rest Bench Installation (Optional)**

1. Place a rest bench bracket on to the lower flange as shown in Figure 13. The flange should sit on the shoulder for the aluminum extrusion and be against the vertical extrusion. See Figure 13.

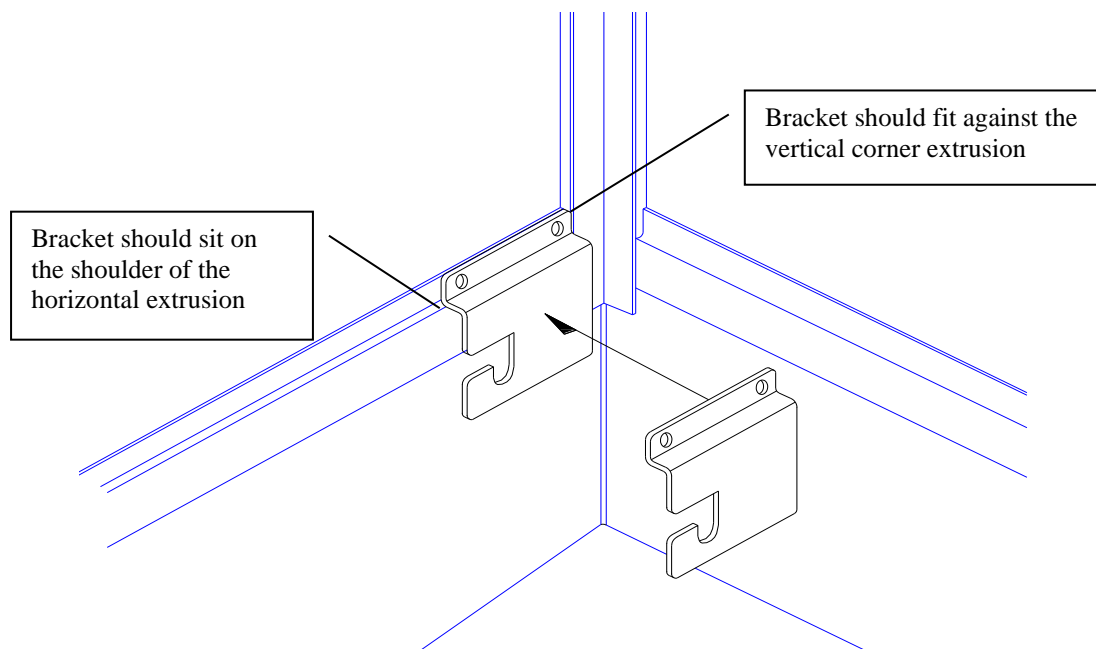

Figure 13.

2. Using a $\frac{1}{4}$ " drill bit and the holes in the rest bench bracket as a guide drill all the way through the division panel keeping the drill bit level and parallel to the back panel.
3. With the bracket held in position place a $\frac{1}{4}$ -20 x 1- $\frac{1}{4}$ " hex head screw in each hole and through the division panel. On the opposite side of the panel install the appropriate bracket (except on end runs where there is none) and secure in place with $\frac{1}{4}$ -20 Nyloc nuts. See figure 14.

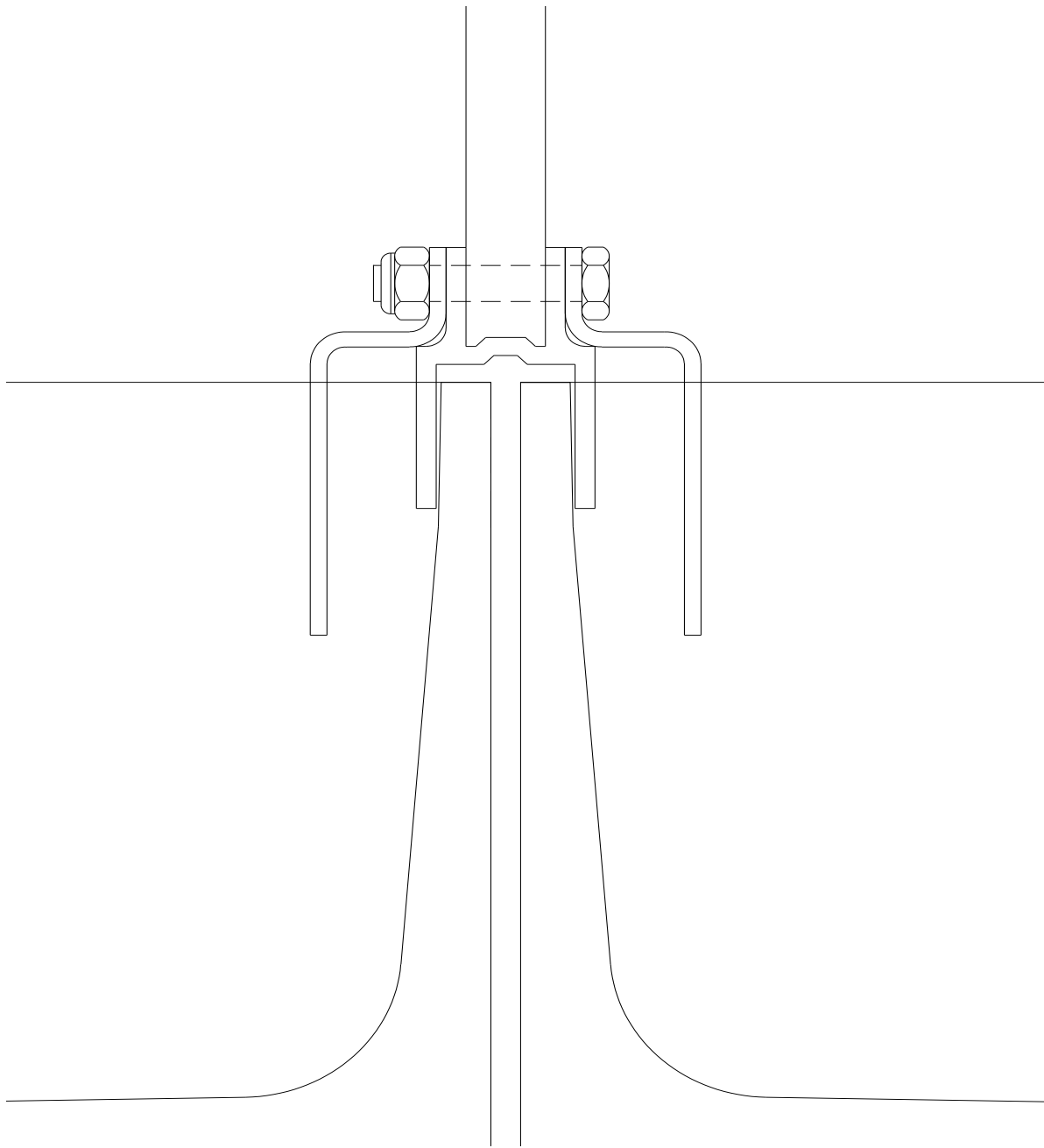

Figure 14

4. Insert (2) 1/2"-13 x 1 3/4" bolts supplied into the threaded plugs as shown in Figure 15.

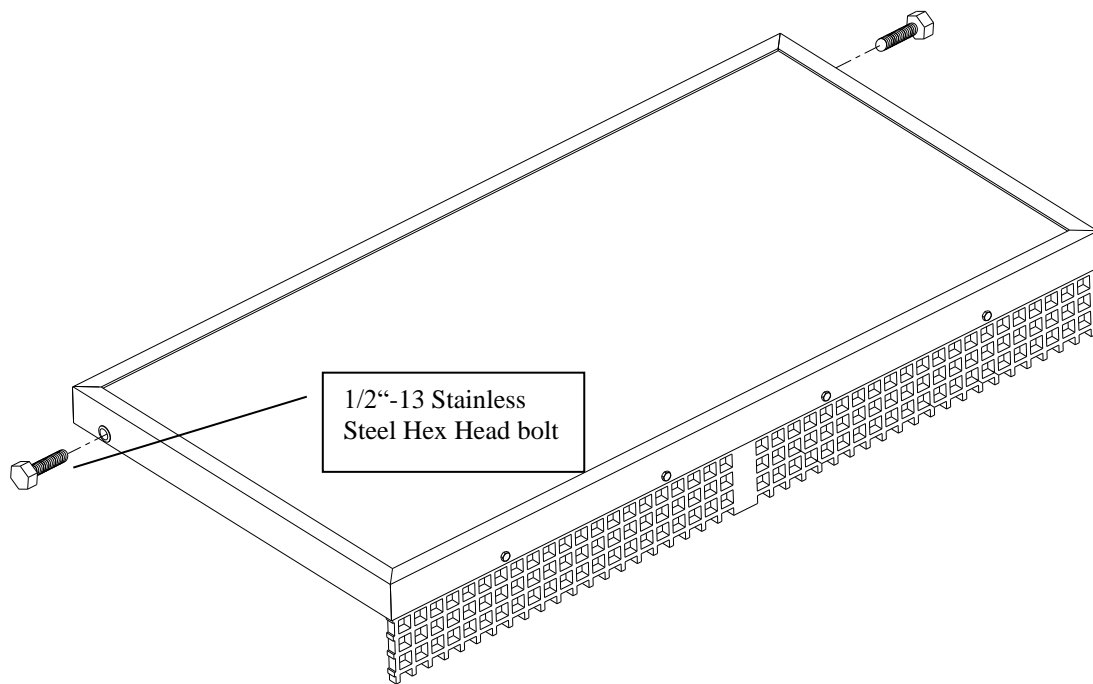

Figure 15

5. Leave the bolts extending out of the plug approximately $\frac{9}{16}$ " as shown. Do not tighten them with a wrench, hand tighten only! See Figure 16.

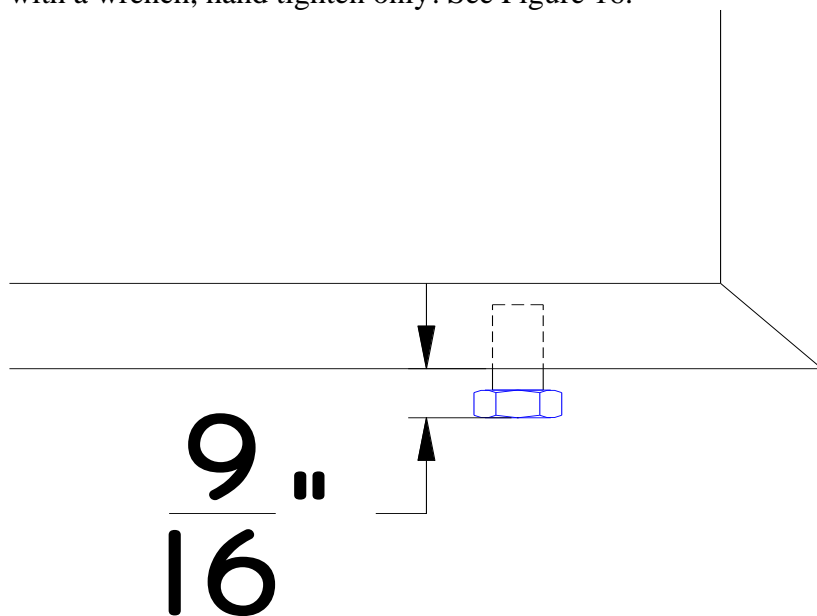

Figure 16.

6. Place the rest bench into positions by situating the bolts into the slot in the front of the rest bench brackets and pushing toward the back of the slot until you feel the bolts drop into the bottom of the slot as shown on Figure 17.

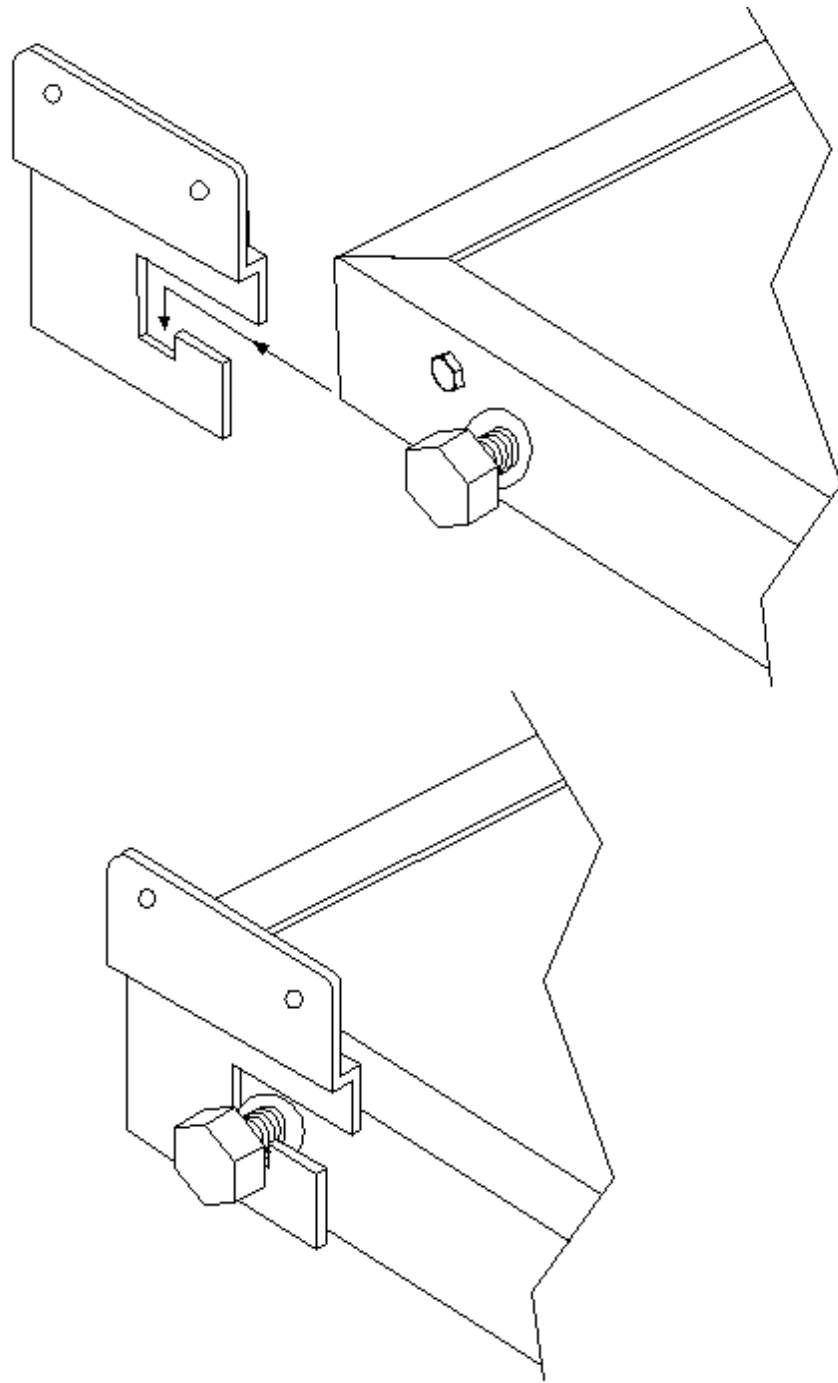

Figure 17.

Section I

Gate/Stall Front Hanging

Chain link Gates/Stall Fronts

1. Attach the filler pipes to the front end of each division panel with two square-round clamps (it takes two halves to make up one clamp) approximately 6" from either end of the filler pipe using the 5/16" x 1-3/4" galv. carriage bolts and 5/16" galv. nuts provided as shown in Figure 18.

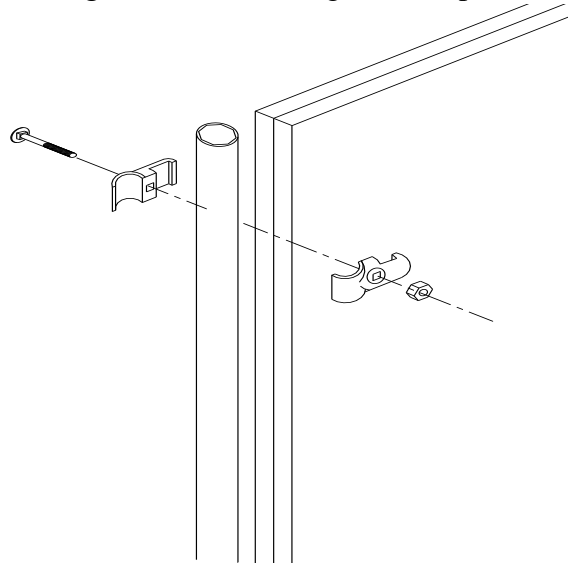

Figure 18.

2. Attach the gate/stall front on the front of each run between the filler pipes with two clamps on each side using the 5/16" x 1-1/2" galv. bolts and nuts provided as shown in Figure 19. Note: It takes two halves to make up one clamp. Attach gates/stall fronts to outside division panels using "panel clamps". All other gates/stall fronts will use "triple clamps". **To help ensure the safety of the animals the round head of the bolt should be assembled toward the inside of the run.** Note: The triple clamps attach two gates/stall fronts together. Therefore, you will have to hang two gates/stall fronts at the same time (see Figures 19 and 20).
3. Finish installing all gates on the lower level.
4. Adjust the gate latch following the instructions in section K, "Gate Latch Adjustment".

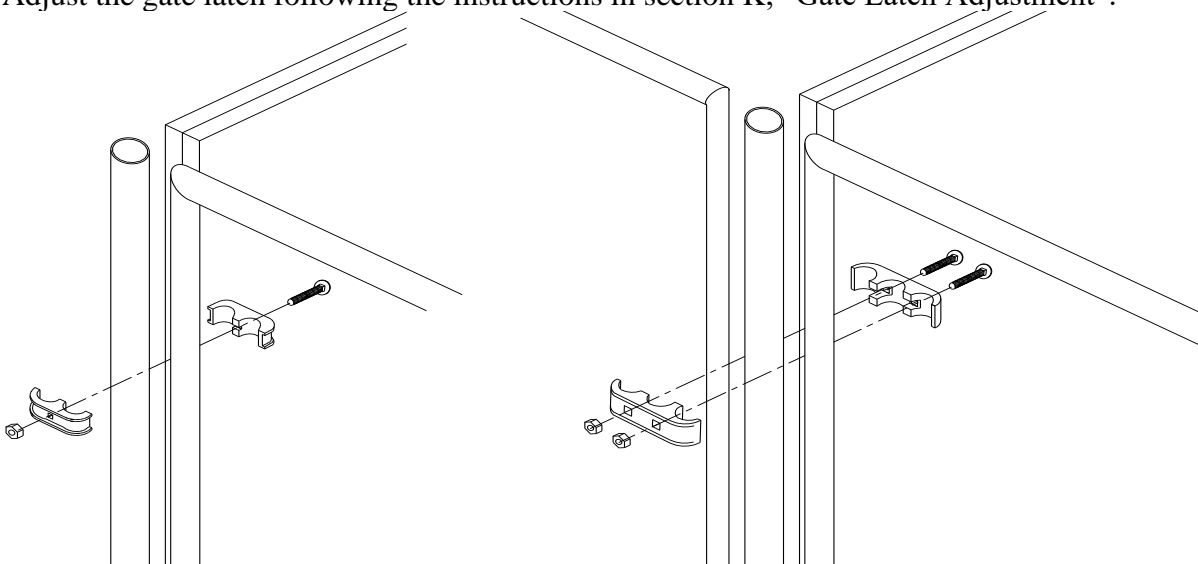

Figure 19.

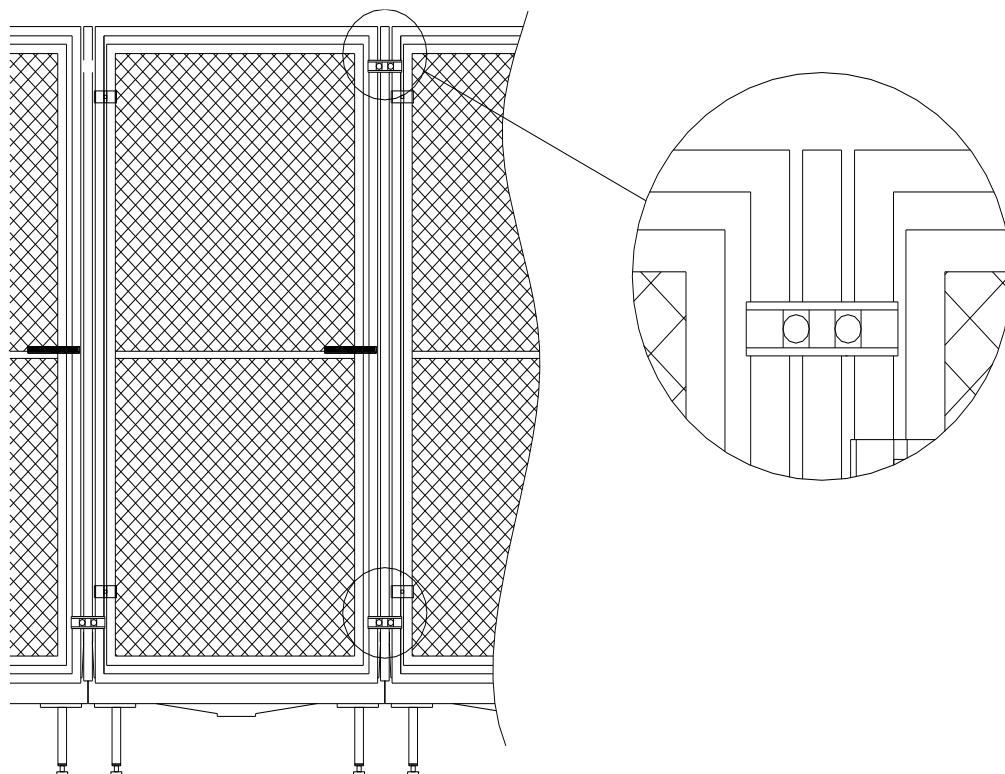
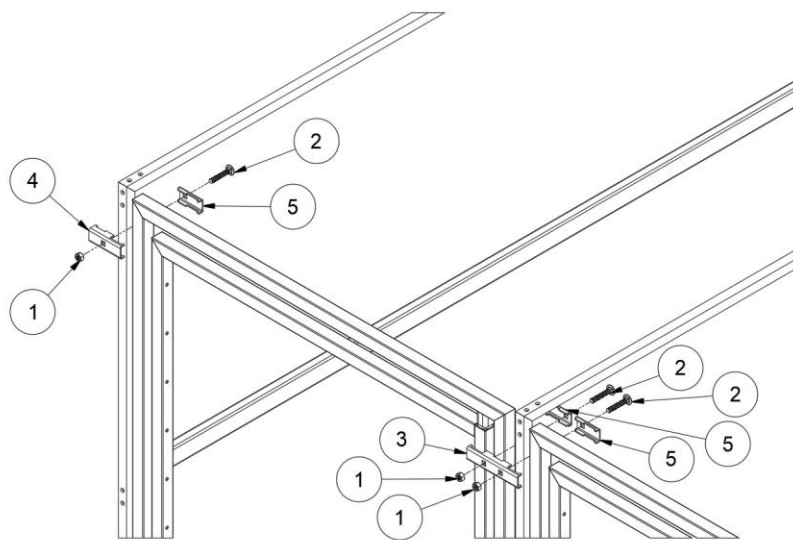

Figure 20.

Stainless Steel Gates/Stall Fronts

1. Attach the gate/stall front on the front of each run between the division panels with three clamps on each side using the 5/16" x 1-3/4" bolts and nuts provided as shown in Figure 21. Note: It takes two halves to make up one clamp. Attach gates/stall fronts to outside division panels using "square – 1" panel clamps". All other gates/stall fronts will use "square – 1" triple clamps". **To help ensure the safety of the animals the round head of the bolt should be assembled toward the inside of the run.** Note: The triple clamps attach two gates/stall fronts together. Therefore, you will have to hang two gates/stall fronts at the same time (see Figure 22).



| Parts List | | |
|------------|-------------|----------------------------------|
| ITEM | PART NUMBER | DESCRIPTION |
| 1 | 424 | 5/16-18 SS nut |
| 2 | 1771 | 5/16-18 x 1.75" SS carriage bolt |
| 3 | 8081 | 1in to 0.75in_Triple Gate Clamp |
| 4 | 8082 | 1in to 0.75in_Double Gate Clamp |
| 5 | 8083 | 1in to 0.75in_Single Gate Clamp |

Figure 21.

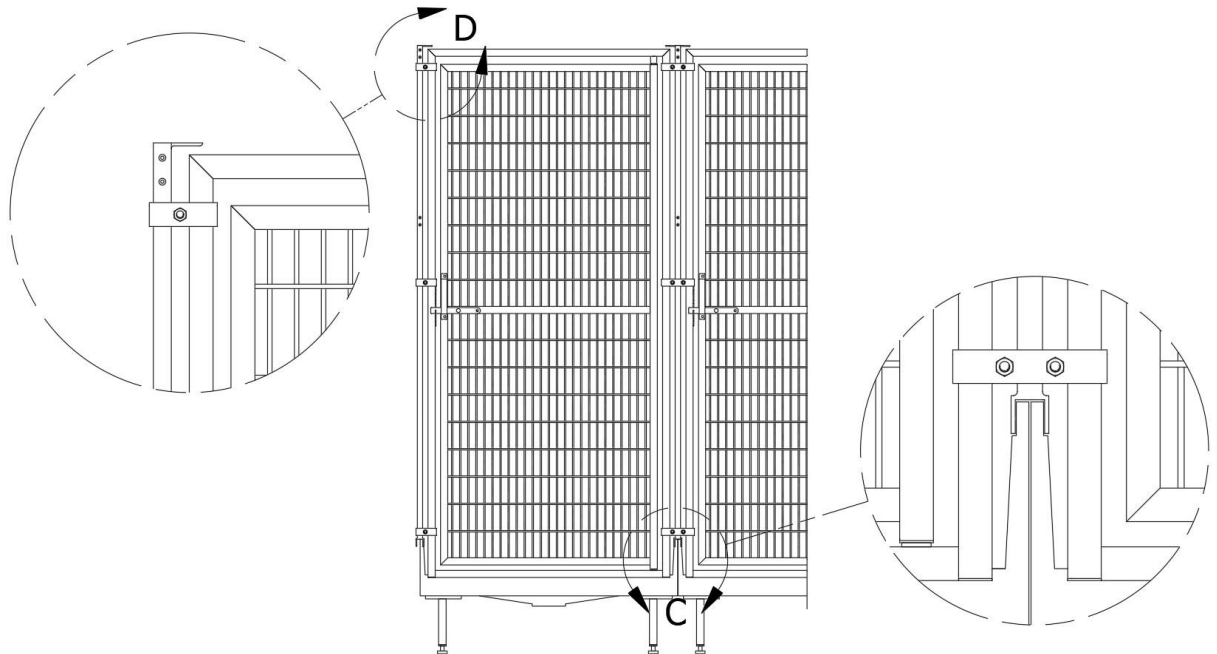

Figure 22.

2. Adjust the gate latch following the instructions in section L, "Gate / Stall Front Adjustment".

Section J Plumbing the System

1. Install the drain fitting into the base units and the walkway units and tighten.
2. Using 2" PVC plumbing, plumb the system by connecting 3 base units together and then running to a vertical drop to the trench drain. Note: all plumbing to be at 1/8" slope per foot.

Section K
Top Cover Installation (Optional)

1. Position top covers onto the top of the division panels.
2. Using Square to Round clamps, 5/16"-18 x 1-3/4" galv. carriage bolts, and 5/16"-18 nuts, connect the back tube of the top covers to the top of the back panels. Place clamps approx. 3" from the division panels. See Figure 23.

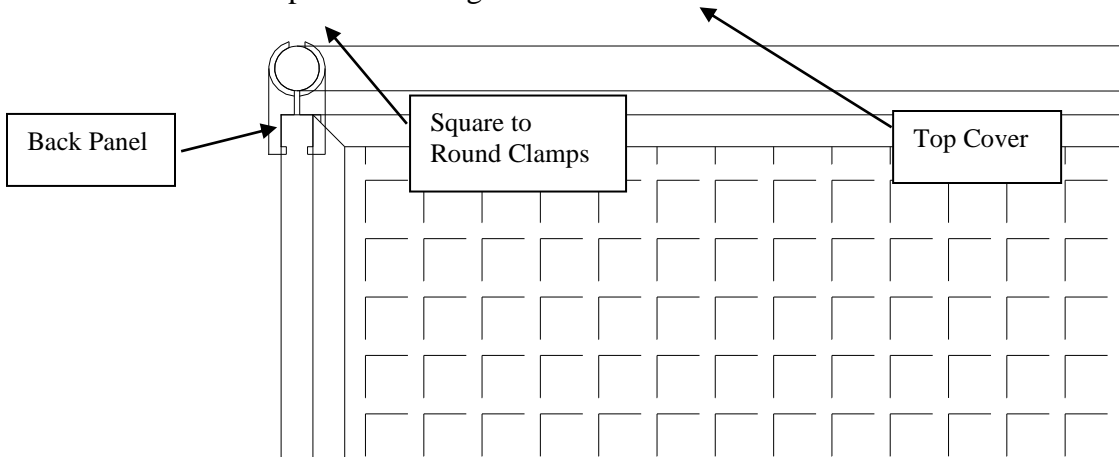

Figure 23

3. Using panel clamps, 5/16"-18 x 1-3/4" galv. carriage bolts, and 5/16"-18 nuts, connect the front tube of the top covers to the top of the gate frames. See Figure 24.

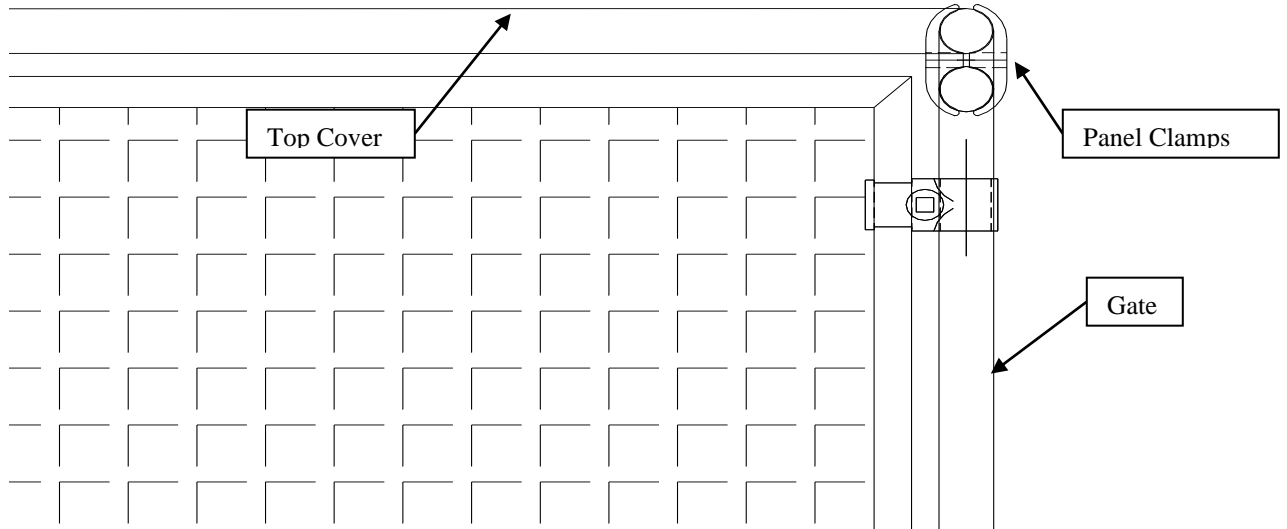

Figure 24.

4. Set rest benches in place if equipped.

Section L Gate / Stall Front Adjustment

During shipment and installation, gate assemblies may be forced out of adjustment. If your gate does not latch automatically when pushed closed, the latch can be adjusted by following these instructions.

Chain link Gate / Stall Front (Reference Figure 25)

During the following adjustment process you may need to move the wire mesh slightly. To do so, use a small block of wood and hammer to tap the wire out of the way.

1. Loosen the latch catch bolt just enough to allow the latch catch to slide up and down.
2. Tap the latch catch up or down until the inside latch bar handle rests on the horizontal brace pipe and the latch bar rests in the bottom of the latch catch.
3. Check to insure the pendant swings freely. If it catches on the latch catch bolt or you've run out of adjustment in the latch catch slot you may have to raise the gate inside of its frame.
4. If the gate needs to be moved, loosen the top and bottom hinge bolts and raise (or lower) both the gate and the top hinge as needed then tighten both hinge bolts.
5. Re-adjust the latch catch.
6. Tighten latch catch bolt

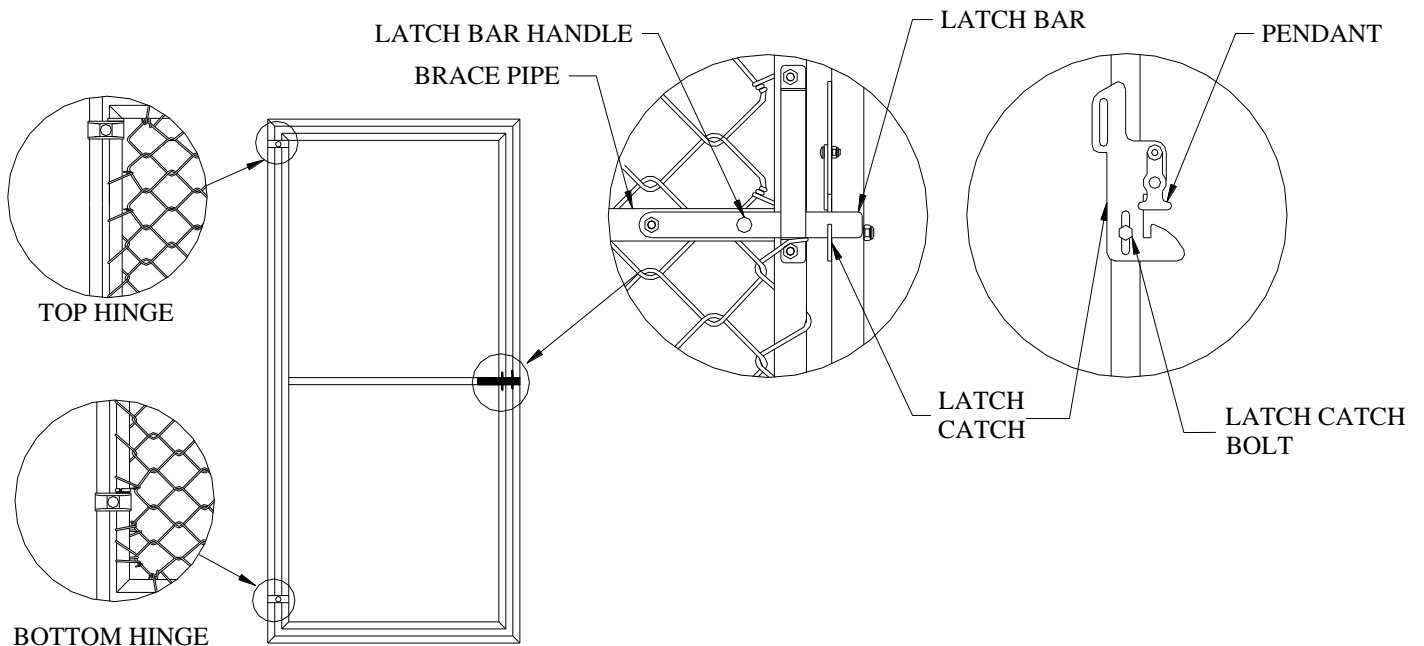

Figure 25.

Stainless Steel Gate / Stall Front (Reference Figure 26)

1. Loosen the latch catch bolts just enough to allow the latch catch to slide up and down.
2. Tap the latch catch up or down until the inside latch bar handle rests on the inside of the keeper and the latch bar rests in the bottom of the latch catch.
3. Tighten latch catch bolts.

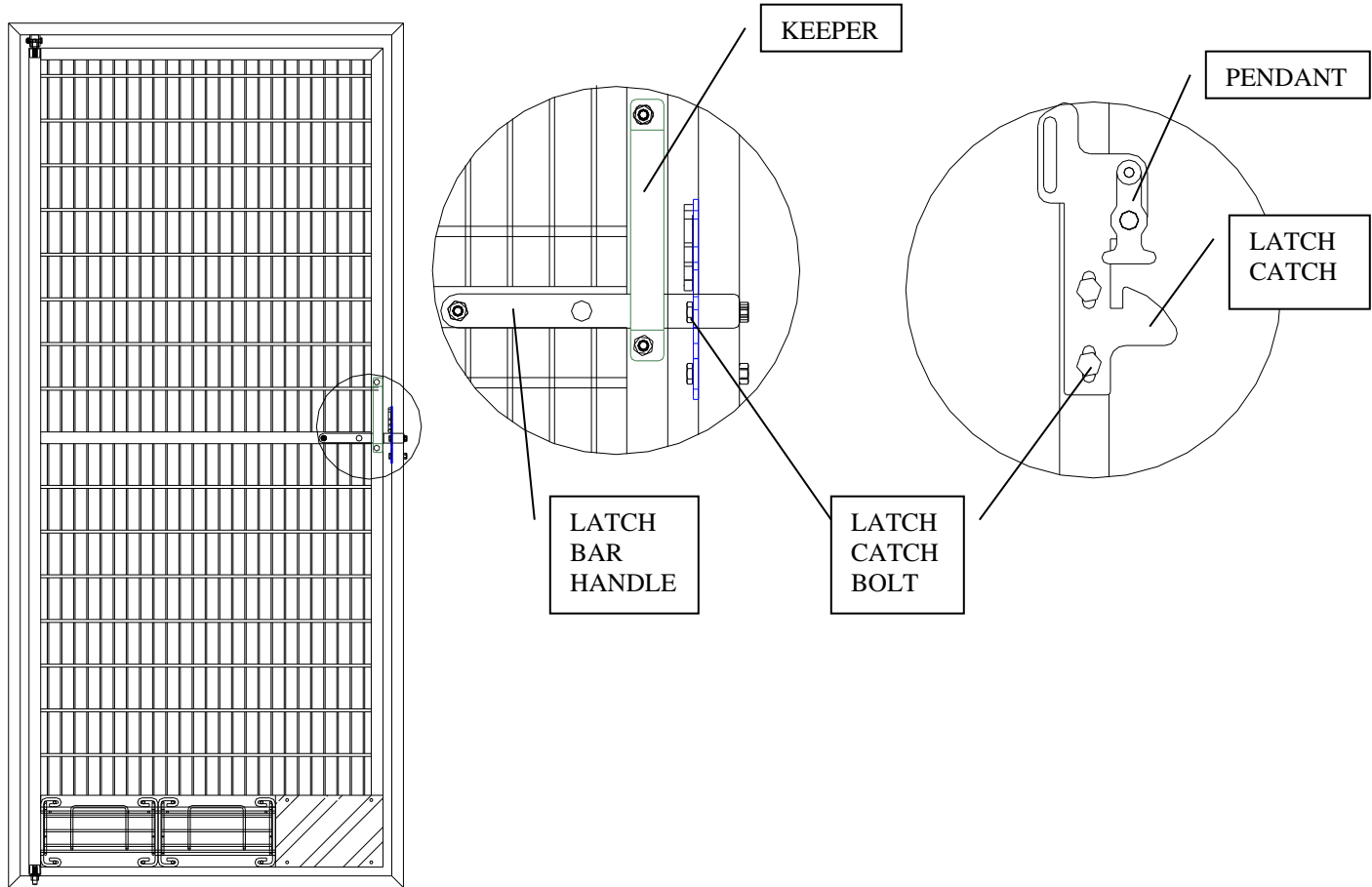

Figure 26.

**Section N
Front Trim Panels (Optional)**

1. After units have been set in place, leveled, and plumbing connected, use a level and chalk line to mark the floor location of Front Trim Panel angle supports. See Fig. 27.

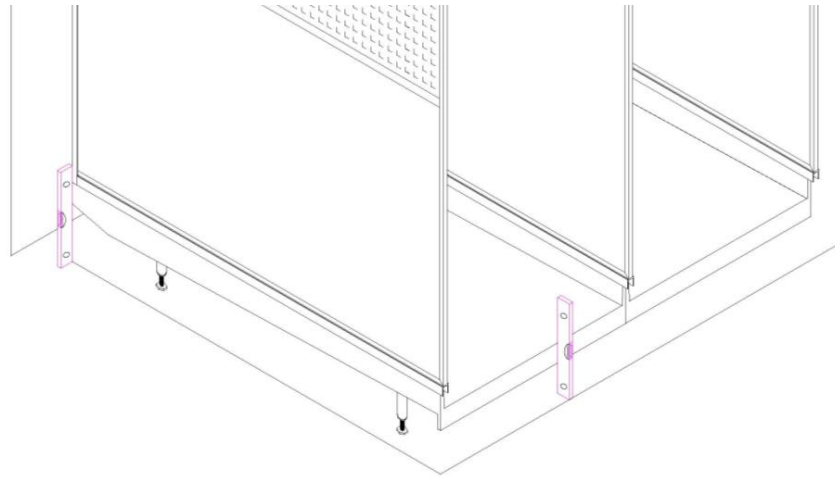

Fig. 27

2. Place aluminum angle supports along chalk lines to determine proper fitment. Some trimming of aluminum angle supports using a 4 1/2" Angle Grinder w/Abrasive Cutoff Wheel may be necessary to achieve proper fitment, depending on individual application. See Fig. 28.

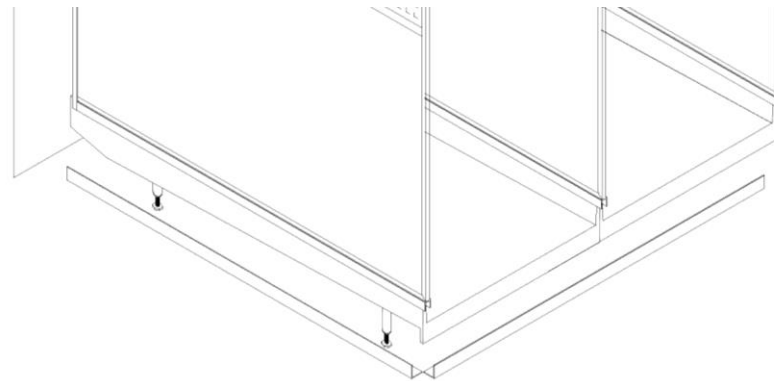

Fig. 28

Note: End Units should have approximately 1 3/8" space between end of angle and end of Ultrabase. See Fig. 29.

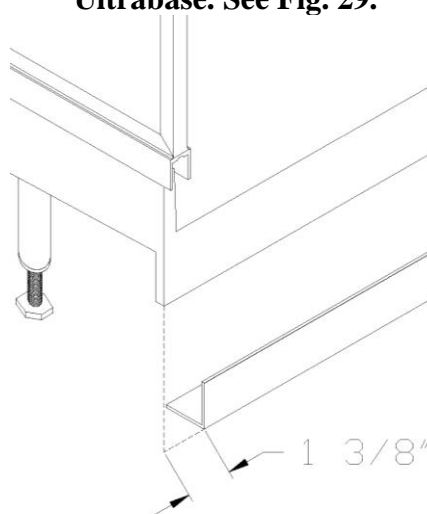

Fig. 29

- After determining proper fitment, use a permanent marker to mark the lower leg of the Front Trim Panel aluminum angle supports for floor anchor locations. These marks should be approximately one inch from each end of the angle and approximately every 6-12" between. See Fig. 30.



Fig. 30

- Using a 5/16" drill bit, pre-drill aluminum angle supports to accept Tapcon Floor Anchors and mark hole locations on the floor surface. See Fig. 31.

Note: Floor anchoring is not required but does add strength and rigidity to the Front Trim Panels.



Fig. 31

- Using a Hammer Drill with a 3/16" Masonry Drill Bit, drill holes at least 2" deep into the concrete floor being careful to avoid expansion joints.
- With a Drill or Impact Driver and a 5/16" Hex Driver Bit, anchor the pre-drilled aluminum angle supports to the flooring using the provided 1/4" x 1 3/4" Tapcon Floor Anchors. See Fig. 32.

Note: Other types of flooring may require different types of fasteners that are not provided.

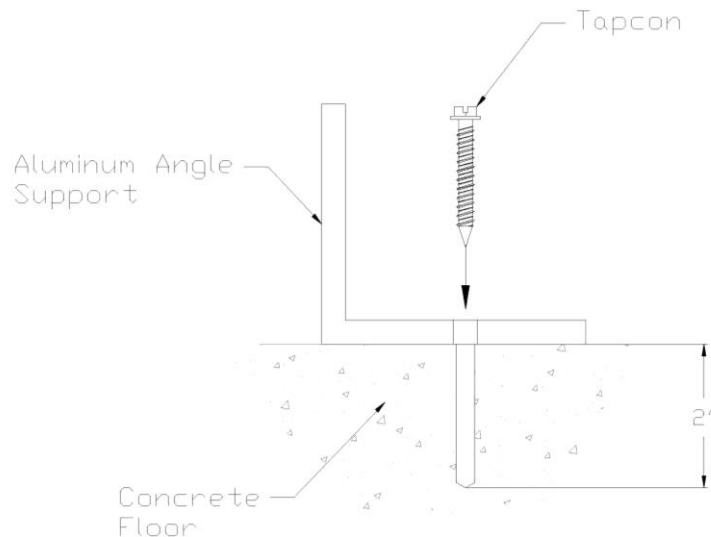
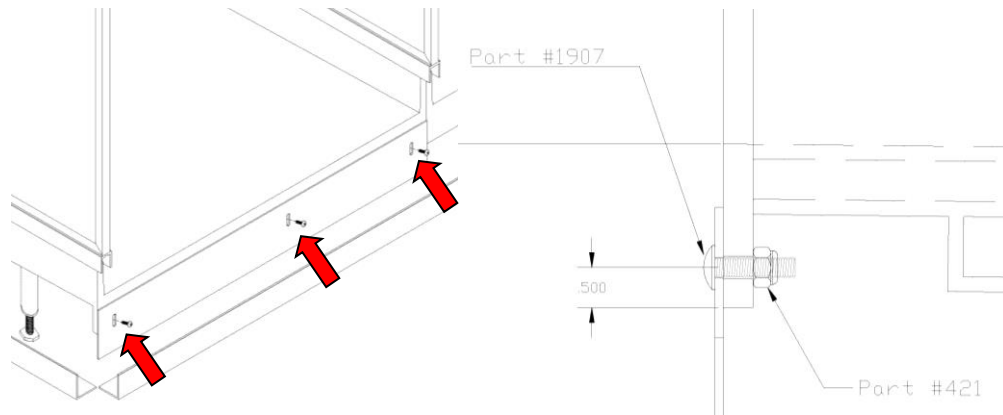

Fig. 32

- Using a 5/16" Drill Bit and a 4" Trim Plate as a guide, drill holes in the front face of the Ultrabase. Holes should be approximately 0.5" up from bottom of the front face. See Figs. 33 and 34.



Figs. 33 and 34

- Attach 4" Trim Plate to the Ultrabase with a Drill or Impact Driver, #2 Phillips Bit, and 7/16" Combination Wrench using the provided 1/4"-20 x 1" Truss head screw(s) and 1/4"-20 Nylok hex nut(s). Gently snug fasteners so trim panel may still be adjusted. See Figs. 33 and 34.
- Place 7 1/2" Tall Front FRP Trim Panel against 4" Trim plate and aluminum angle supports, adjust 4" Trim Plate up or down if necessary and tighten Trim Plate 1/4"-20 x 1" Truss head screw(s).

Caution: Do not overtighten or damage to fiberglass Ultrabase may occur!

- Secure 7 1/2" Tall Front FRP Trim Panel to 4" Trim Plate and aluminum angle supports using the provided 10 x 1 1/2" TEK hex washer head sheet metal screw(s). See Figs. 35 and 36.

Note: If not anchoring to the floor use the #10 x 5/8" TEK hex washer head sheet metal screw(s) to attach the angle floor supports to the back of the 7 1/2" Tall Front FRP Trim Panel first.

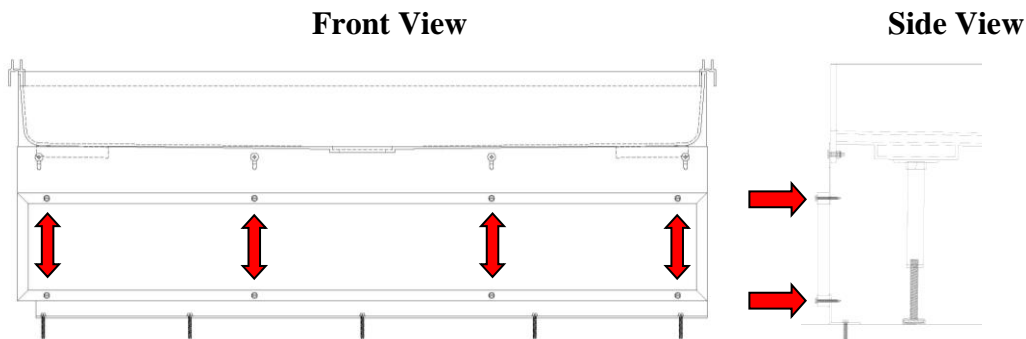

Figs. 35 and 36

11. Attach 2" x 2" x 10 1/2" Aluminum Angle to the back side of end Front Trim Panels using provided #10 x 5/8" TEK hex washer head sheet metal screw(s), leaving an 11/16" reveal on angle. See Figs. 37 and 38.

Note: Aluminum angle may need trimmed depending on height of Ultrabase when leveled.

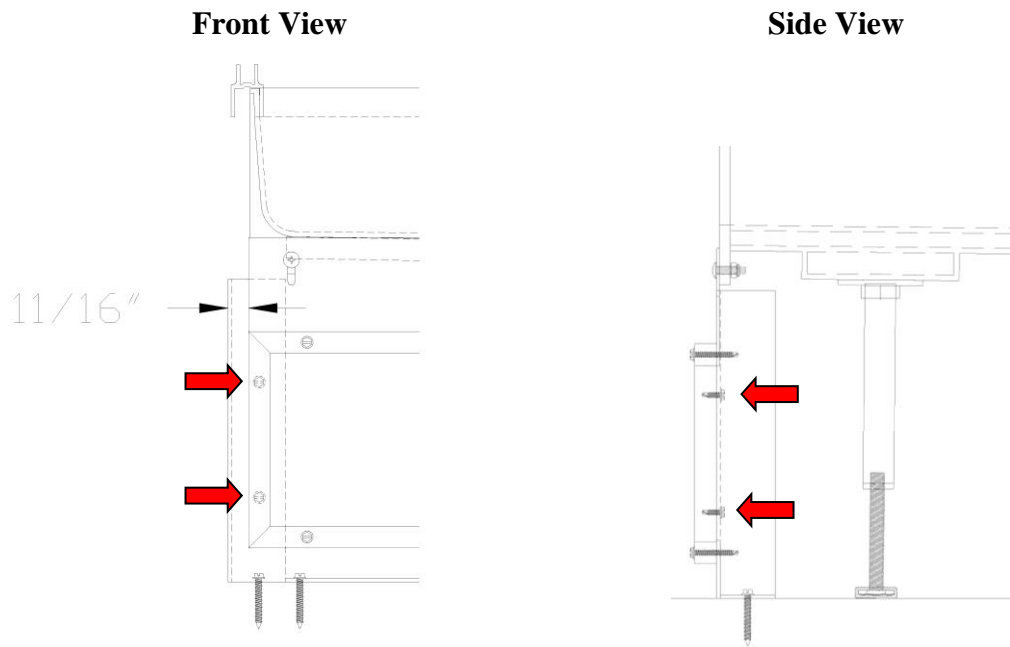

Figs. 37 and 38

Section O Side Trim Panels (Optional)

1. Use a level and chalk line to mark the floor location of Side Trim Panel aluminum angle supports. See Fig. 39.

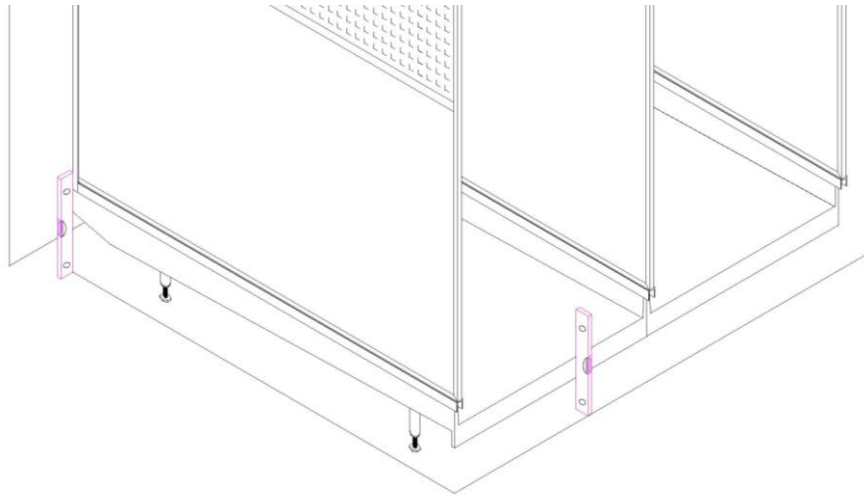

Fig. 39

2. Place aluminum angle supports along chalk lines to determine proper fitment. Some trimming of aluminum angle supports using a 4 1/2" Angle Grinder w/Abrasive Cutoff Wheel may be necessary to achieve proper fitment, depending on individual application. See Fig. 40.

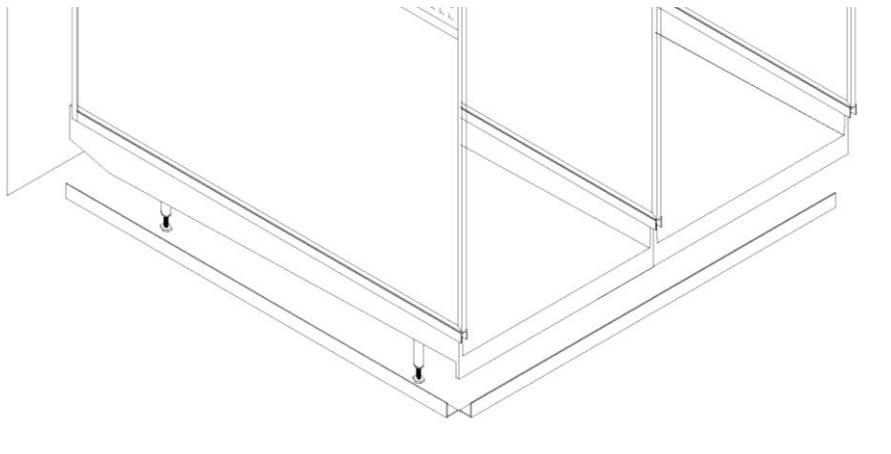

Fig. 40

3. After determining proper fitment, use a permanent marker to mark the lower leg of the Side Trim Panel aluminum angle supports for floor anchor locations. These marks should be approximately one inch from each end of the angle and approximately every 6-12" between. See Fig. 41.



Fig. 41

- Using a 5/16" Drill Bit, pre-drill aluminum angle supports to accept Tapcon Floor Anchors and mark hole locations on the floor surface. See Fig. 42.

Note: Floor anchoring is not required but does add strength and rigidity to the Trim Panels.



Fig. 42

- Using a Hammer Drill with a 3/16" Masonry Drill Bit, drill holes at least 2" deep into the concrete floor being careful to avoid expansion joints.
- With a drill or Impact Driver and a 5/16" Driver Bit, anchor the pre-drilled aluminum angle supports to the flooring using the provided 1/4" x 1 3/4" Tapcon Floor Anchors. See Fig. 43.

Note: Other types of flooring may require different types of fasteners that are not provided.

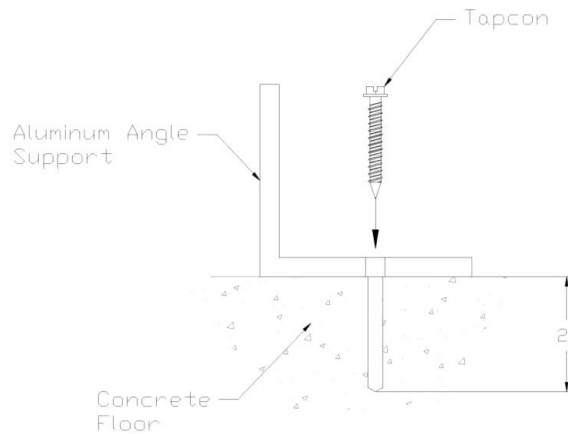
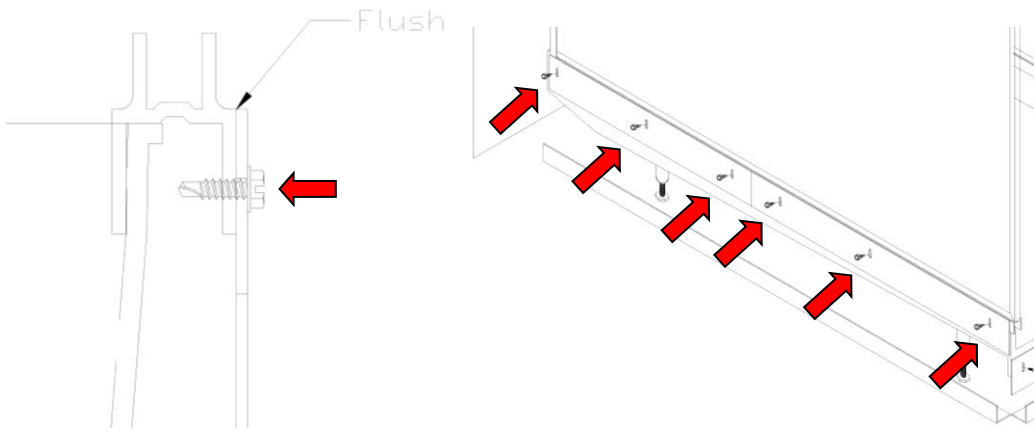

Fig. 43

- Align 4" Trim Plate flush with the bottom aluminum extrusion on the Ultrabase division panel and secure using the provided #10 x 5/8" TEK hex washer head sheet metal screw(s). See Figs. 44 and 45.

Note: A combination of 36" and 48" Trim Plates may be necessary to properly support 13" Tall Side FRP Trim Panel depending on size of Ultrabase.



Figs. 44 and 45

8. Secure 13" Tall Front FRP Trim Panel to 4" Trim Plate and aluminum angle supports using the provided 10 x 1 1/2" TEK hex washer head sheet metal screw(s). See Fig. 46.

Note: If not anchoring to the floor use the #10 x 5/8" TEK hex washer head sheet metal screw(s) to attach the angle floor supports to the back of the 13" Tall Front FRP Trim Panel first.

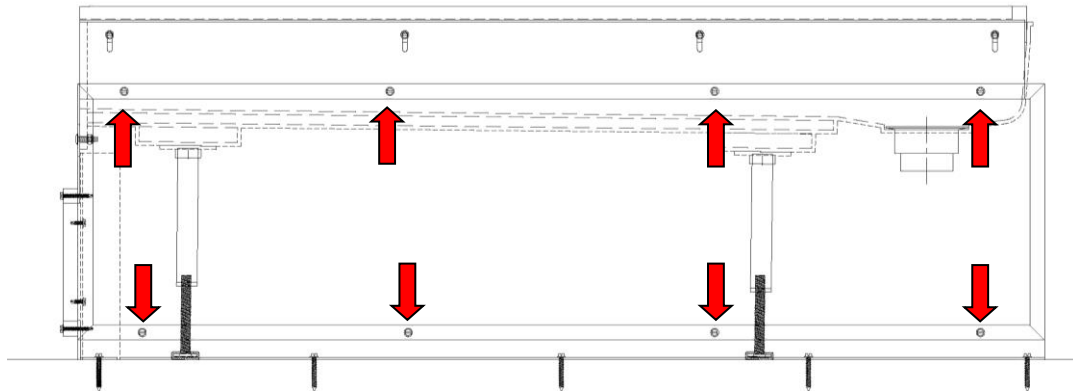

Fig. 46

9. Secure 13" Tall Front FRP Trim Panel to the 2" x 2" x 10 1/2" Aluminum Angle attached to the back side of the Front Trim Panels using the provided 10 x 1 1/2" TEK hex washer head sheet metal screw(s). See Fig. 47.

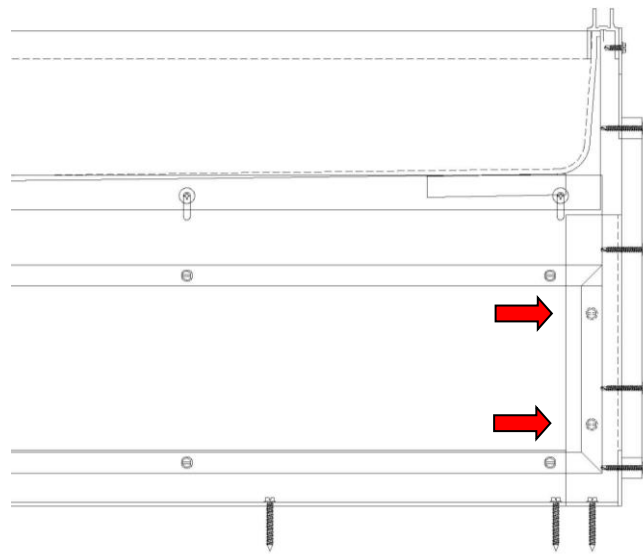
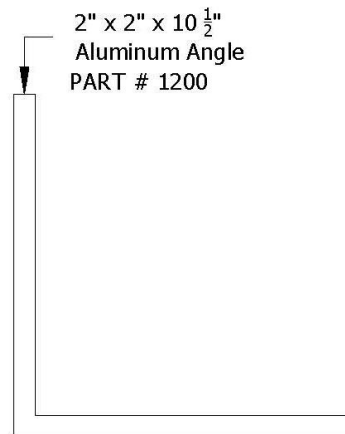
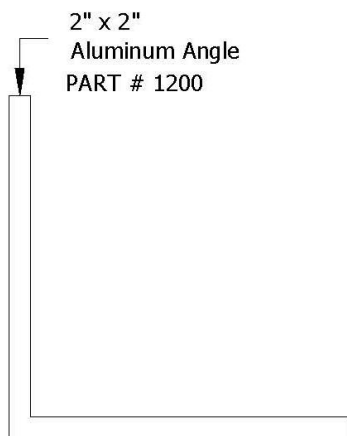
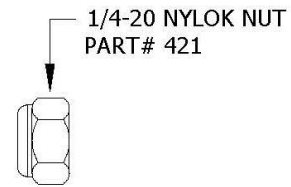
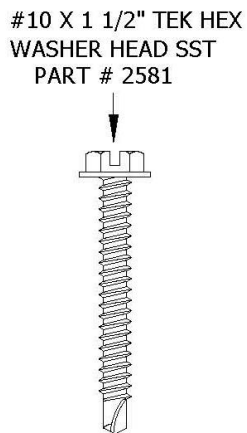
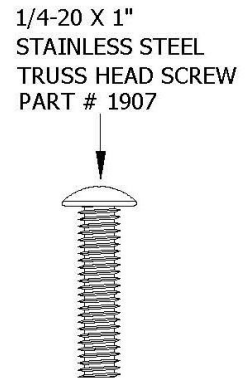
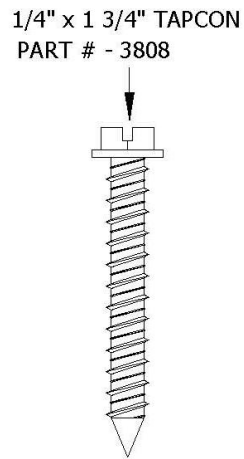
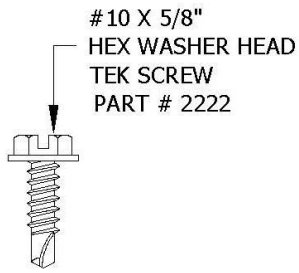

Fig. 47

Maintenance

Over time, your Mason kennels might require adjustments, lubrication, or replacement parts in order to remain in top working condition. We recommend a yearly maintenance schedule to lubricate door hinges, adjust gate locks and any other moving parts. A standard, industrial grease works well. If your kennels should need any replacement parts, our professional sales engineers will be happy to review your original order and assist you.



TRIPLE CLAMP - 1"
#3120

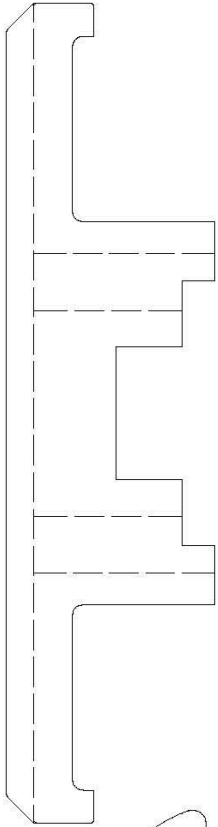

TRIPLE SS CLAMP - 1"
#8081

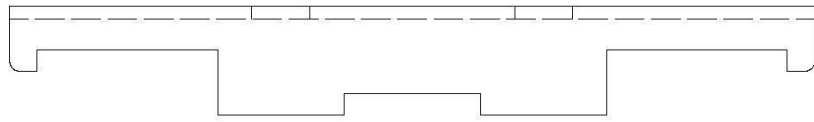

DOUBLE CLAMP - 1"
#3119

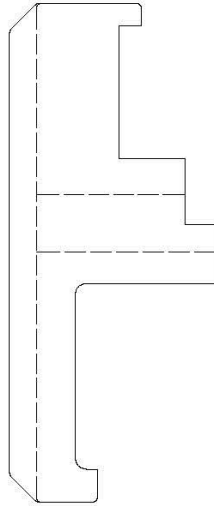

DOUBLE SS CLAMP - 1"
#8082

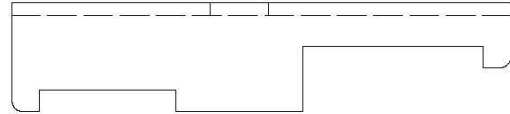

SINGLE SS CLAMP - 1"
#8083

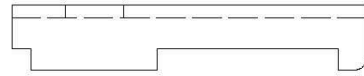

SINGLE CLAMP - 1"
#3118

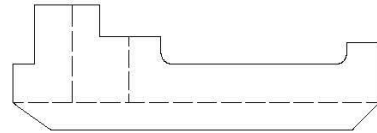

TRIPLE CLAMP
#328

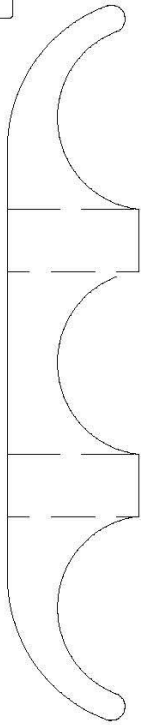

SQUARE TO
ROUND CLAMP
#1468



PANEL CLAMP
#330

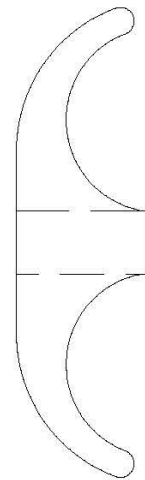

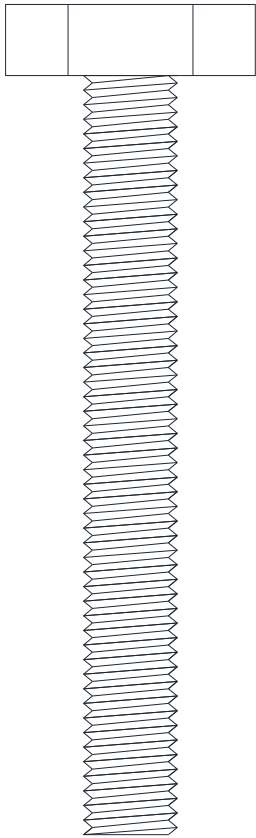

1/2-13 HEX LEVELER LEG
ID# 2134

1/2-13 X 1-3/4" HHCS.
PART # 3914

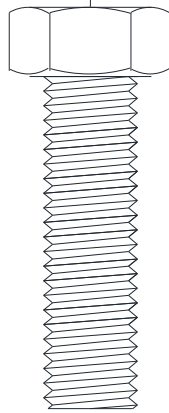

#12 X 1" SELF TAPPING
SCREW HEX HEAD
PART # 891

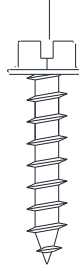

#10 X 5/8" TEK HEX
WASHER HEAD SST
PART # 2222

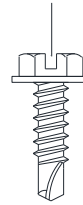

1/2-13 NUT
PART # 428

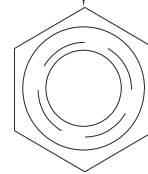

1/4-20 X 1-1/4" HHCS.
PART # 368

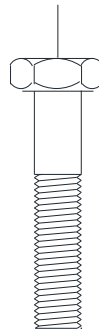

5/16-18 NUT
PART # 423

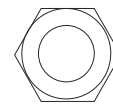

1/4-20 NUT
PART # 422



5/16" X 1-1/2"
GALVANIZED
CARRIAGE BOLT
PART # 356

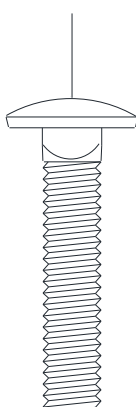

5/16" X 1-3/4"
GALVANIZED
CARRIAGE BOLT
PART # 357

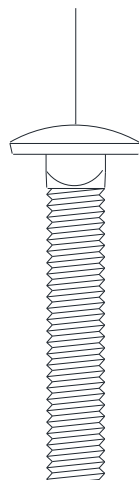

5/16" X 1-1/2"
STAINLESS STEEL
CARRIAGE BOLT
PART # 1955

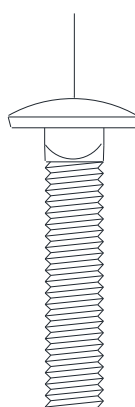

5/16" X 1-3/4"
STAINLESS STEEL
CARRIAGE BOLT
PART # 357

