

Installation Instructions for Luxury Suites

Introduction

Thank you very much for your investment in Mason kennels. We take great pride in providing our customers with the highest quality animal enclosures combined with an enjoyable ordering experience. The following instructions will assist you with proper assembly, cleaning, and maintenance of your Mason kennels. It is important to follow these guidelines in order to receive the best results and maximum life from your investment.

Assembly

The following pages will show you how to assemble your new Mason kennel. Since every order is custom built to your specifications, the instructions are designed to show the various methods used to assemble our kennels and some of the demonstrations may not apply to your order. Be sure to use the enclosed scale drawings at the end of this document of the provided hardware to ensure proper identification and usage.

Hardware

Depending on your Kennel project you may have some or all of the following hardware:

Part #	Description	Part #	Description
5290	#10-32x 5/8" TEK screw(s)	3808	1/4" x 1-3/4" Tapcon
1368	#12 x 2" Hex screw(s)	2449	Sealant

Note: Wall mounting hardware is shown only for reference purposes and is not included

Section A Extrusion and Panel Identification

Refer to the floor plan supplied.
Depending on the nature of your Kennel Project you will have letter designations on the components as shown by the example in Figure 1.

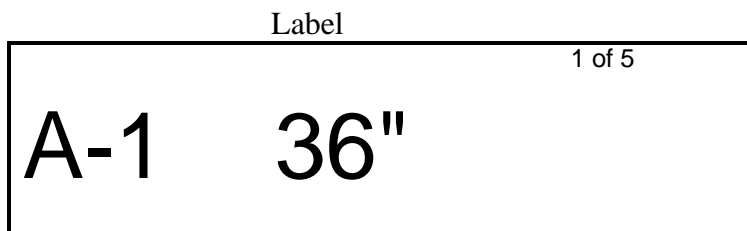

Figure 1

There are 5 different extrusion profiles used in the Luxury Suites. Some profiles are used with and without notches. The extrusions are individually identified with a lettered sticker along with the length of the extrusion. The profiles are as shown below in figures 2-8:

Profile A:

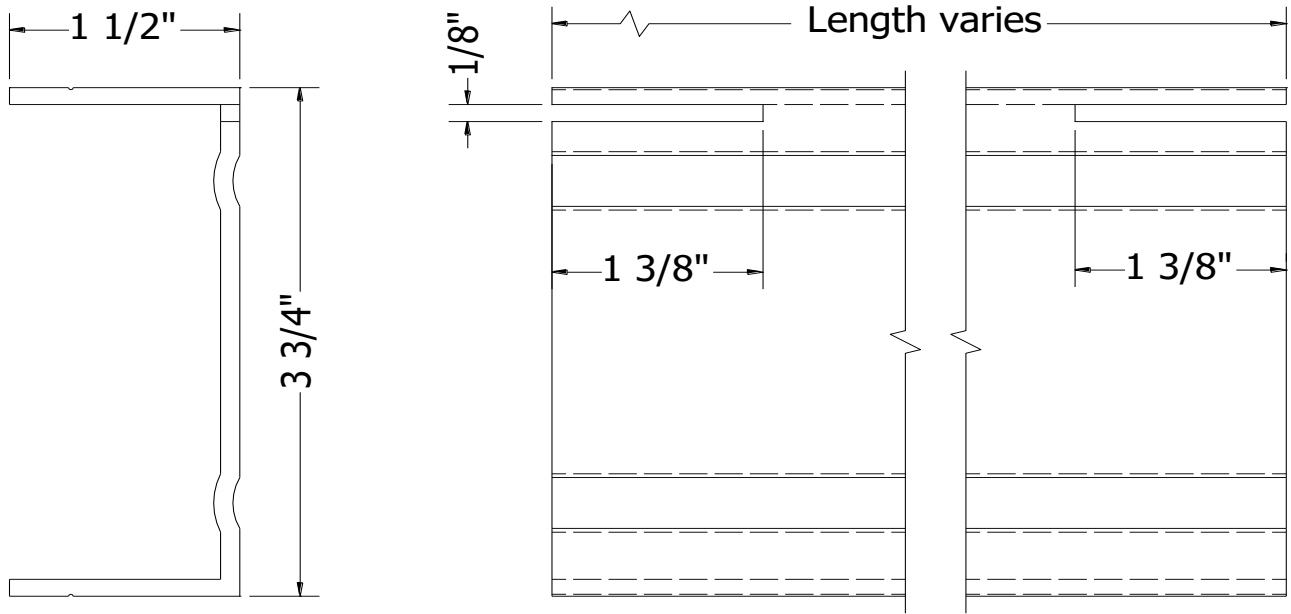

Figure 2

Profile B:

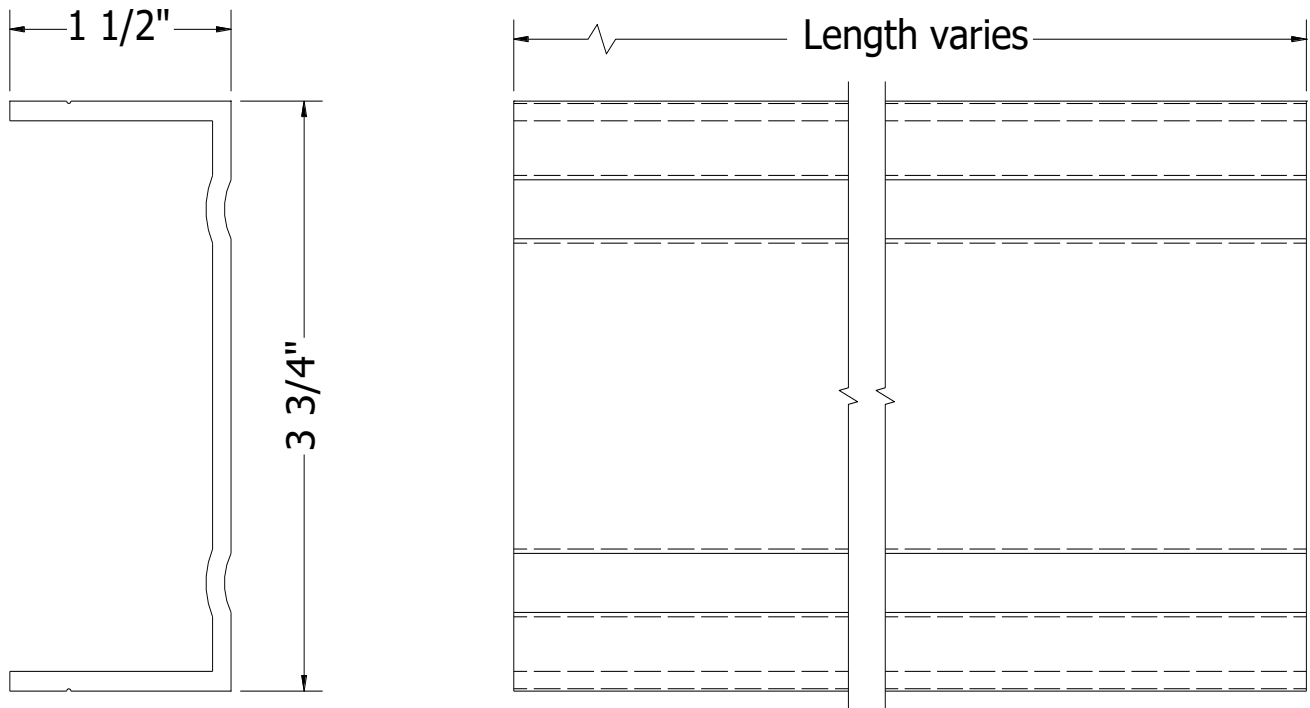

Figure 3

Profile C:

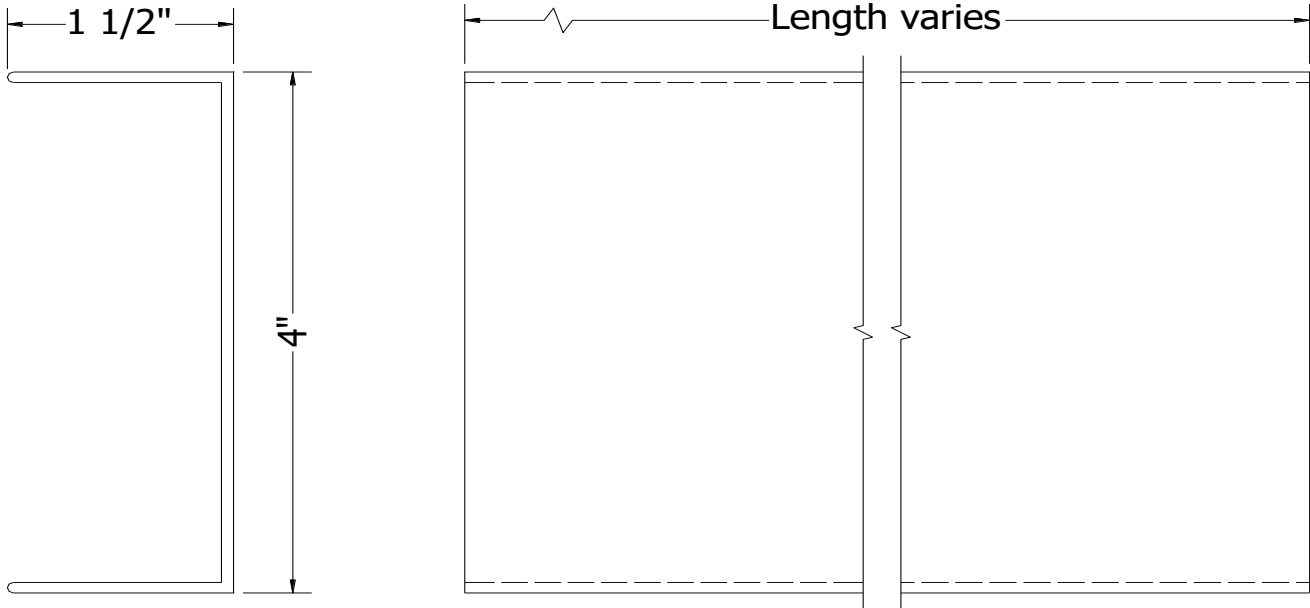

Figure 4

Profile D:

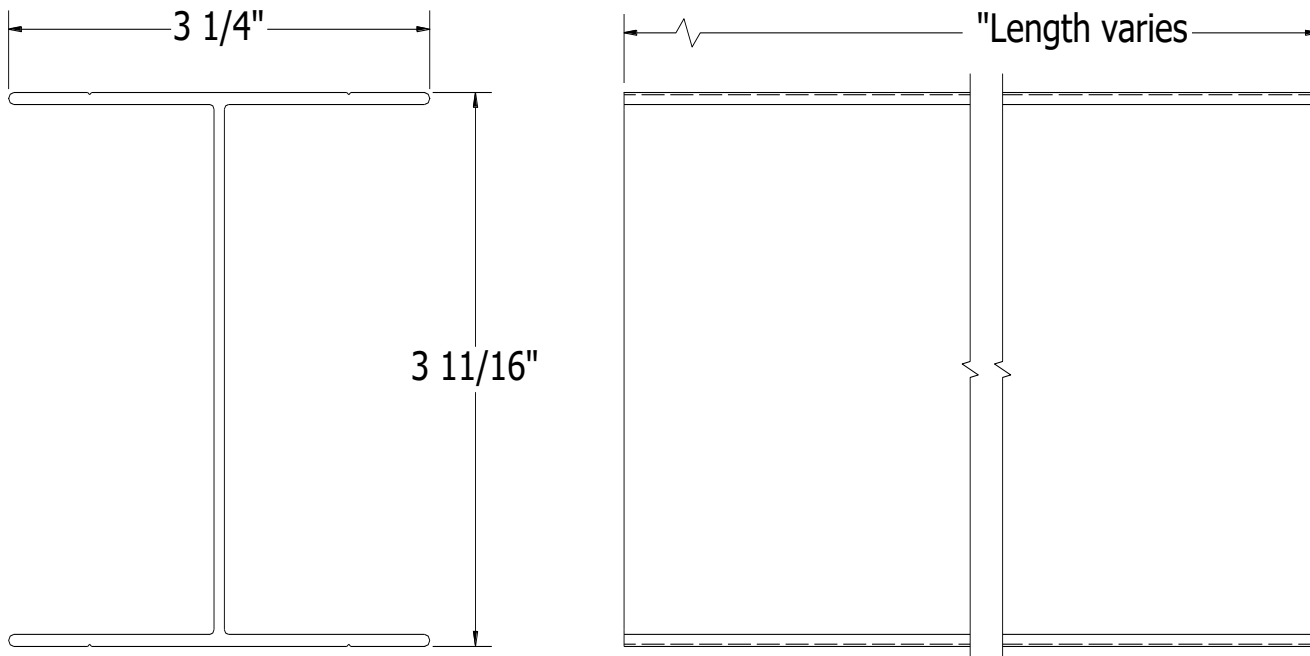

Figure 5

Profile E:

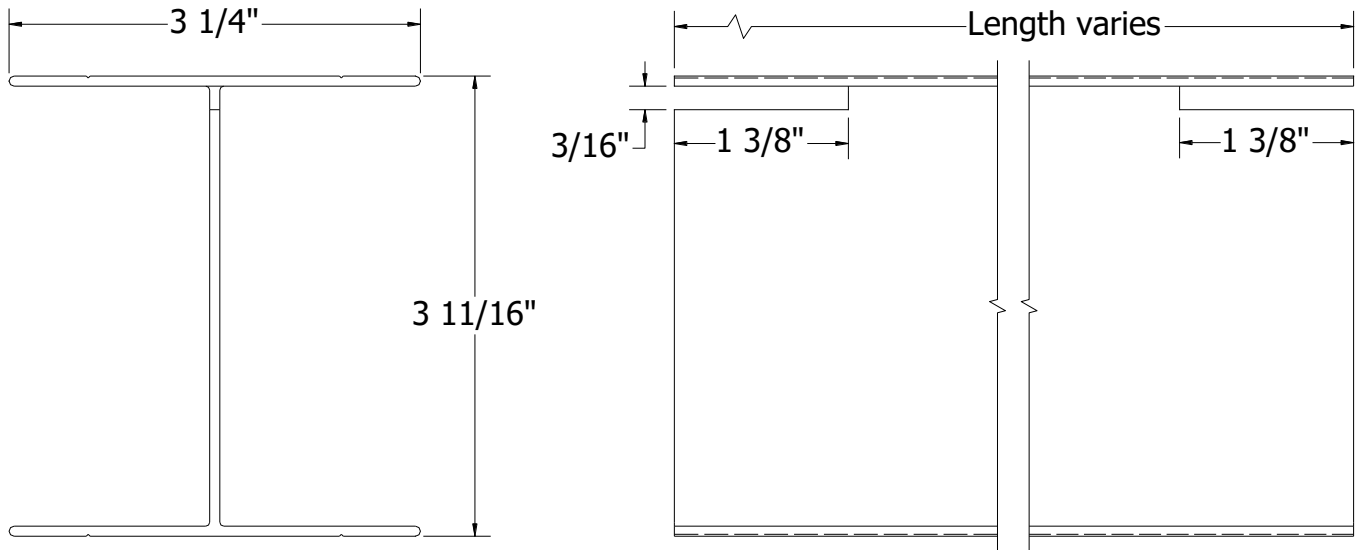

Figure 6

Profile F:

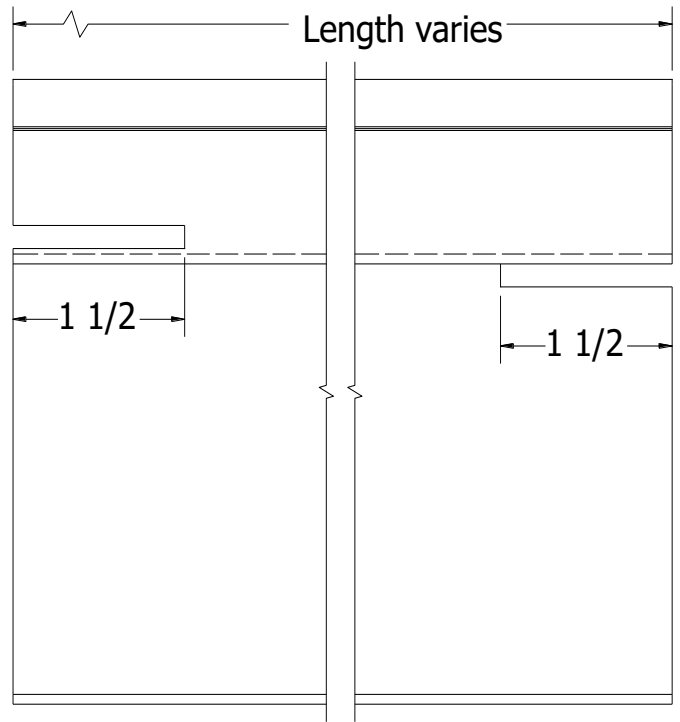
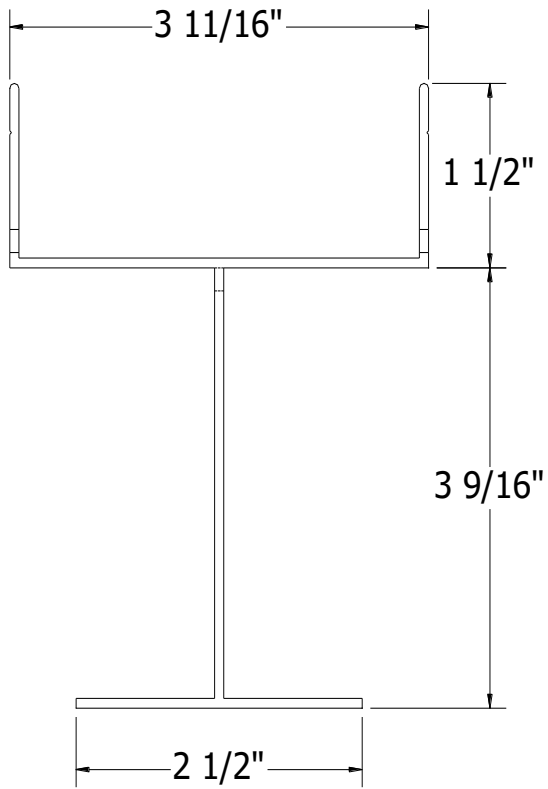

Figure 7

Profile G:

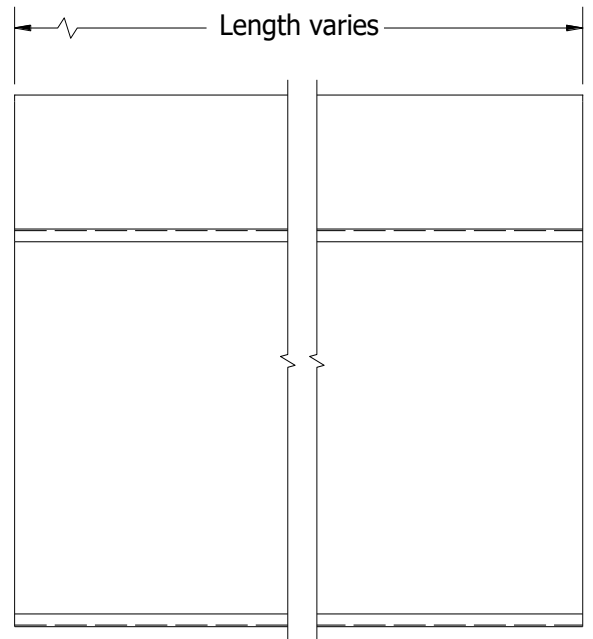
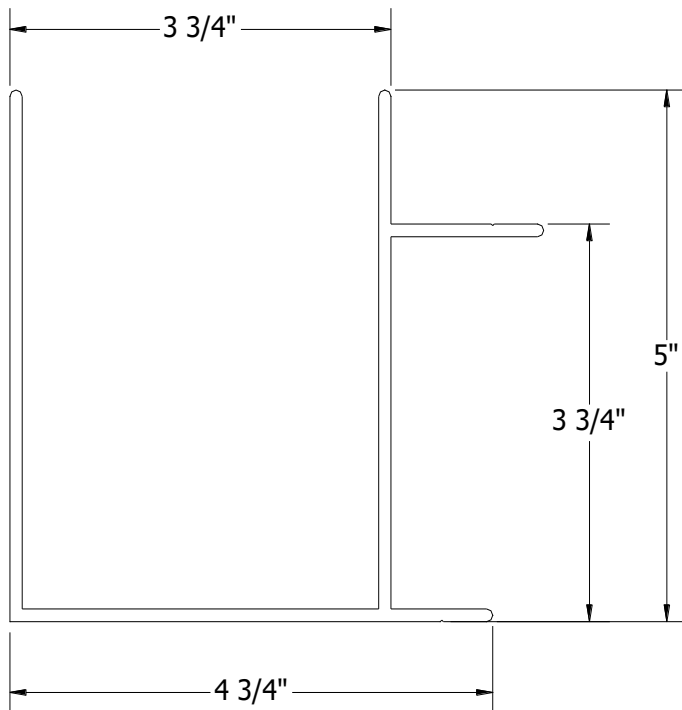

Figure 8

Panel Identification: individual panels are labeled along one edge per the designation on your drawings.

**Section B
General Assembly Information**

1. The installation of this products requires at least two installers. Do not try to do it alone.
2. The extrusions must overlap to fit together properly, care must be taken to keep overlaps the same at the bottom level as they are at the middle level. It will make a difference as to how your runs go together if you do not align the extrusions properly and in some cases they may not go together at all. See figure 9.

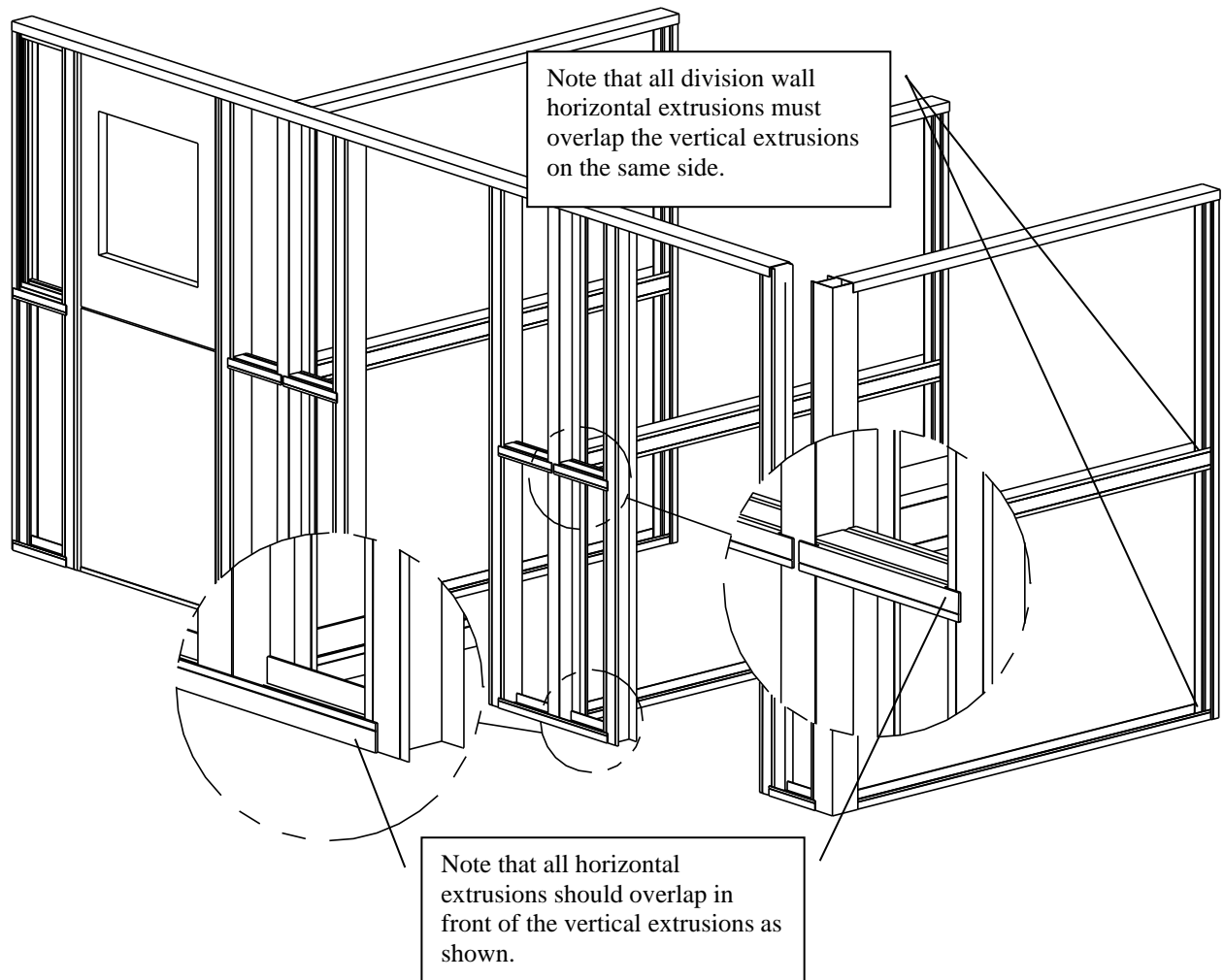

Figure 9

Section C Division Wall Assembly

Begin at one end of the system referring to your floor plan.

1. Layout on the wall where the vertical “B” extrusions should be positioned. Your drawing will show system centerlines, you will need to make sure your extrusions are centered on those dimensions.
2. **Note:** if there is a coving along the floor you will need to do one of three things - 1. Notch the coving so the extrusion comes down to the floor, 2. Notch the extrusion to fit over the coving. 3. Cut the extrusion so that it ends at the top of the coving. We recommend notching the coving, cutting the extrusions in the field risks scratching the anodized finish on the extrusions and can detract from the appearance of your system.
3. Fasten each appropriate “B” extrusion to the wall at the proper location using screws, either Tapcon anchors or #12 x 2” screws (Not Supplied) depending on the wall construction. See figure 10. You will need to pre drill the extrusion with a ¼” drill bit for each screw. We recommend at least 3 screws or Tapcons per extrusion.

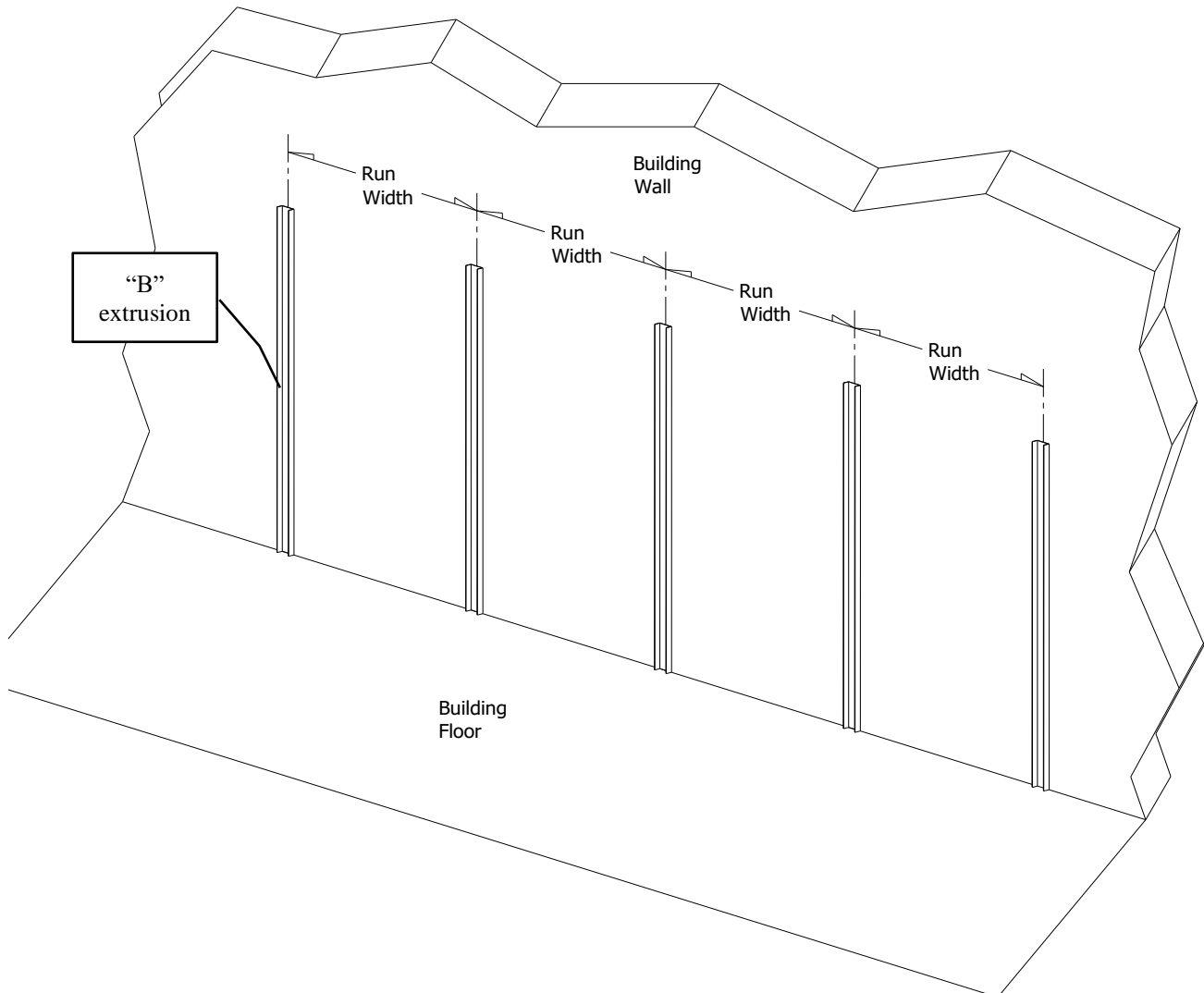

Figure 10

4. If your system is using Silvis Seals you must apply them to the LOWER “A” channels now.. Apply the Silvis Seal to the appropriate “A” channels by removing approximately 2 ft. of backing tape. Starting at the end of the “A” channel, apply the Seal being careful to orient the Seal in line with the “A”. Lay the rest of the Seal on to the channel. Carefully pull the remaining backing tape from the “Seal” and using light pressure adhere it to the aluminum as shown in Figure 11.

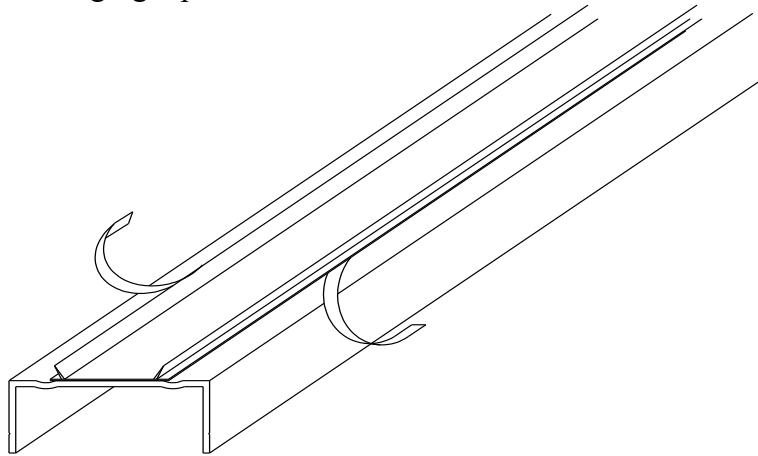

Figure 11

5. Position the “A” channels for the division walls onto the floor and interlocking with the “B” channels that you have previously fastened to the wall. For division walls at the ends of the system the floor “A” channel should be to the inside of the run. This will allow the vertical corner extrusion (“G” profiles) to fit properly. The “A” channels should be slid onto the “B” as far as they can go. See figure 12.

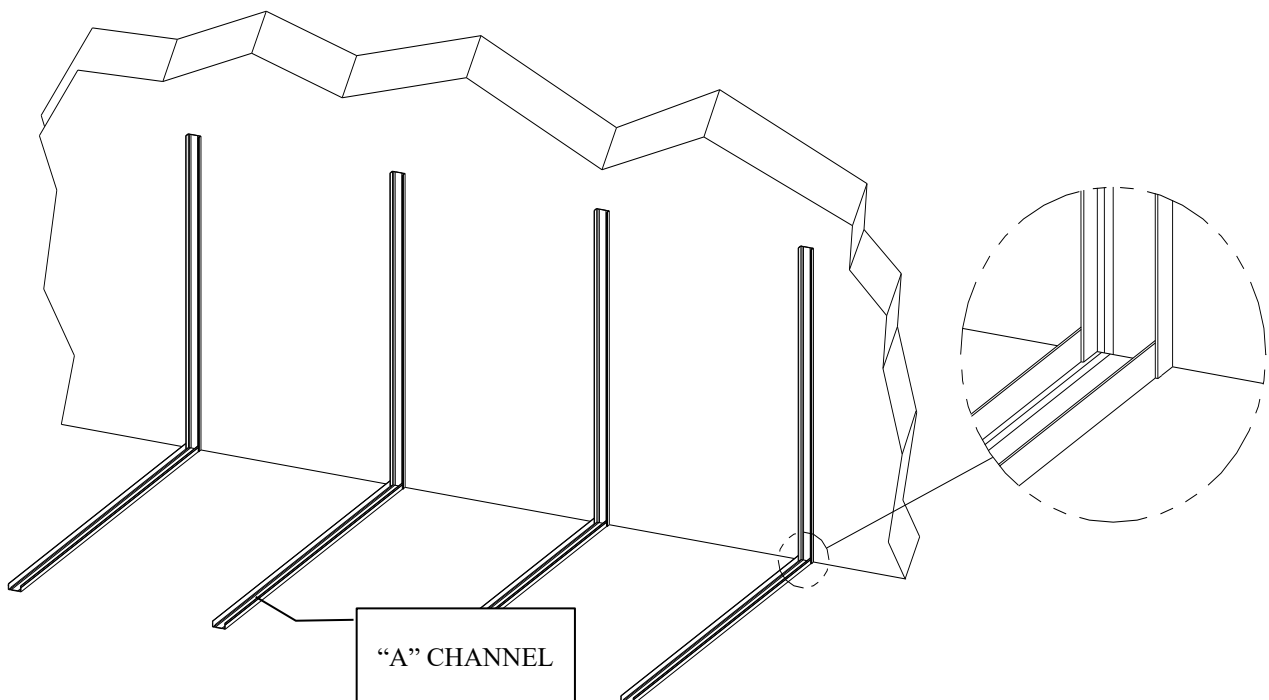

Figure 12

6. Insert the lower filler panels into the “A” and “B” extrusions. Do this for all division walls. See figure 13.

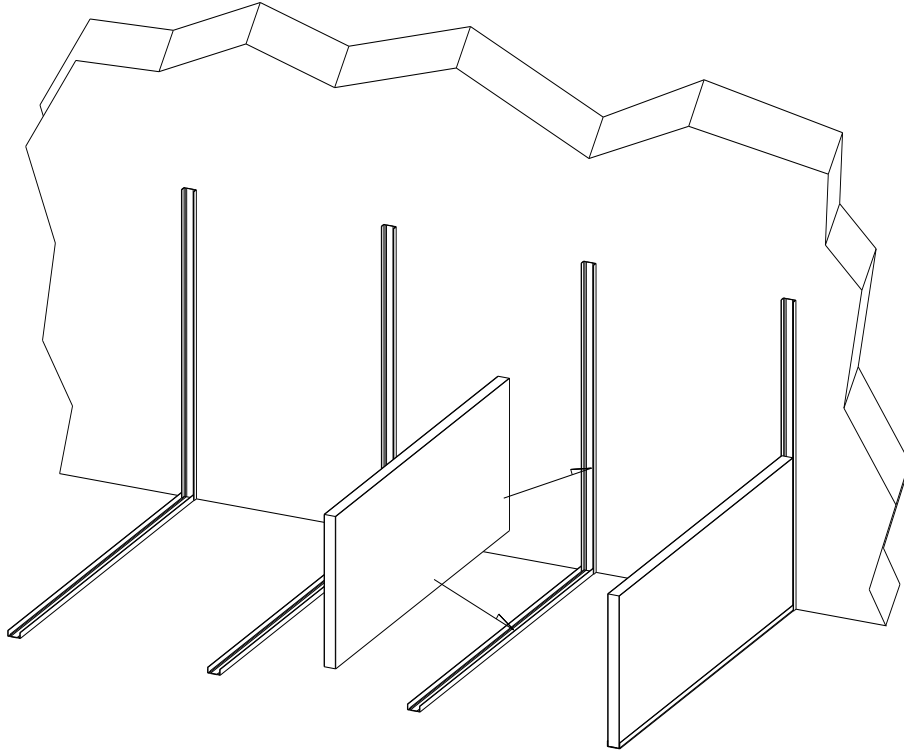

Figure 13

7. While applying downward pressure to the filler panels secure all of the “A” channels to the “B” channels with the supplied TEK screws. See figure 14.

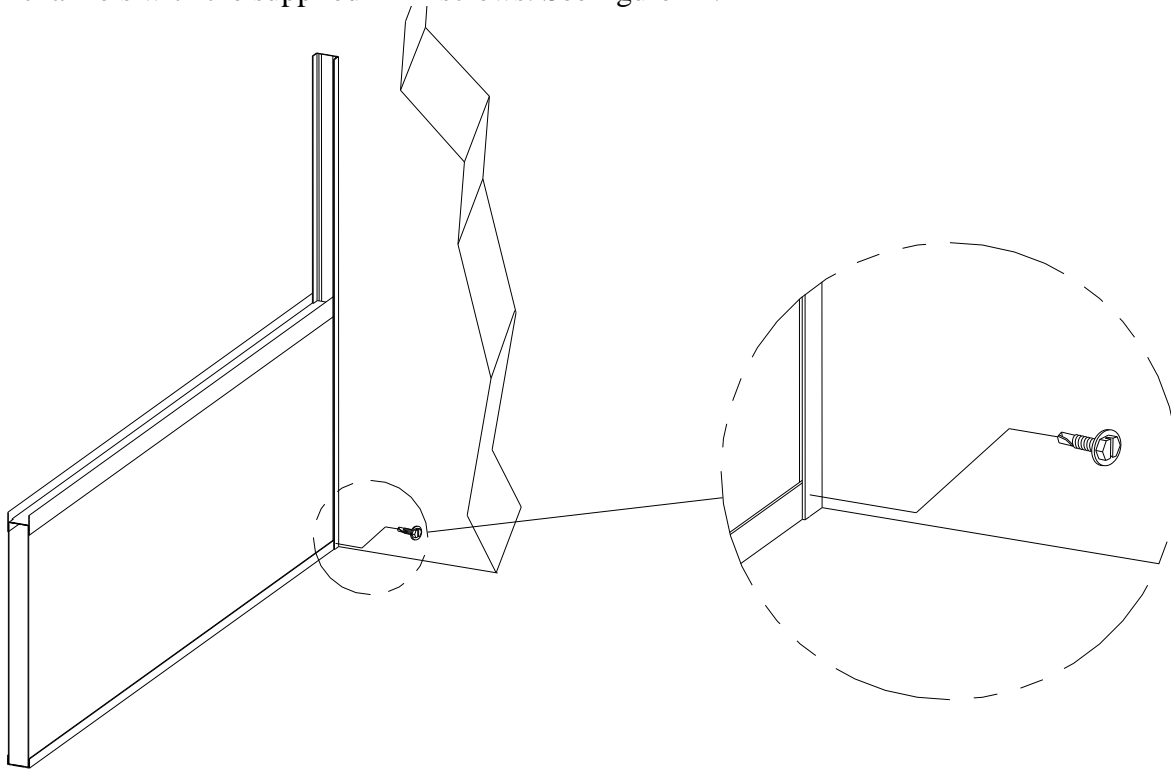

Figure 14

8. Install the “E” channels for the division walls on to the filler panel installed in step 8. Make sure the channels overlap to the same side as the bottom “A” channels. See figure 15.

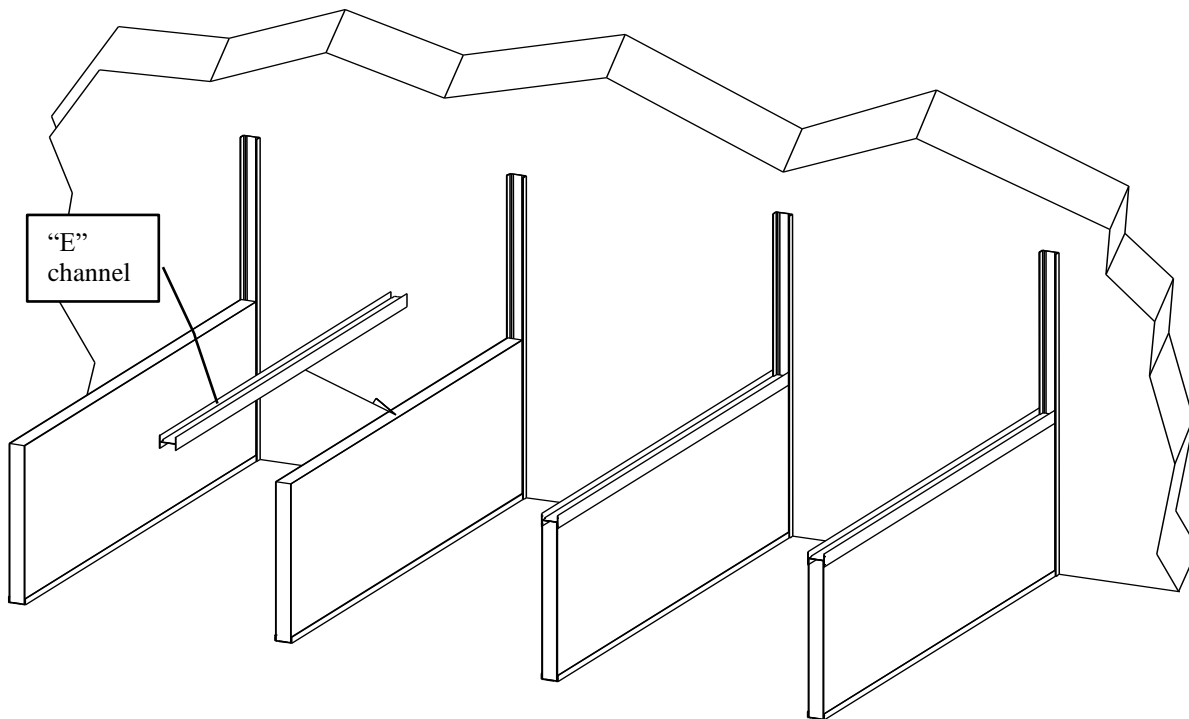

Figure 15

9. Install the upper filler panels into the “E” and “B” channels. See figure 16.

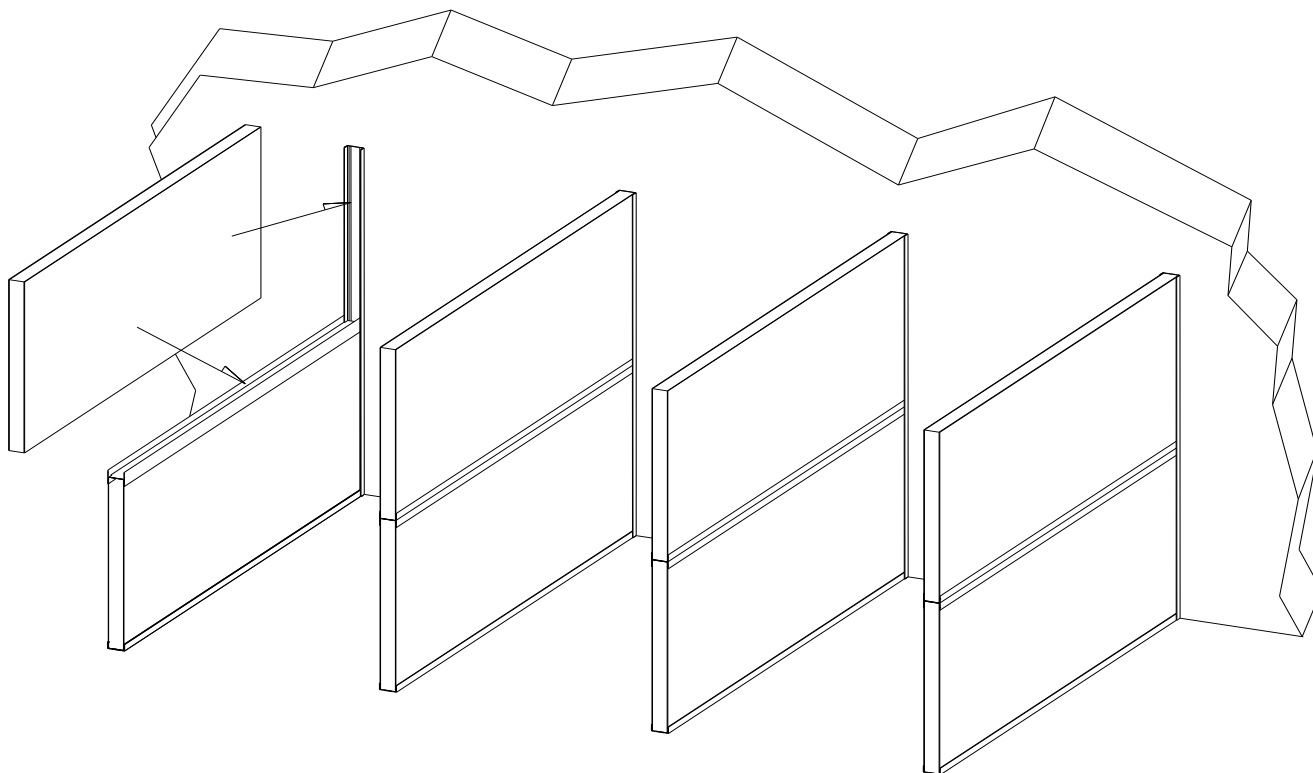

Figure 16

10. Fasten the “E” channels to the “B” channels with the supplied TEK screws. See figure 17.

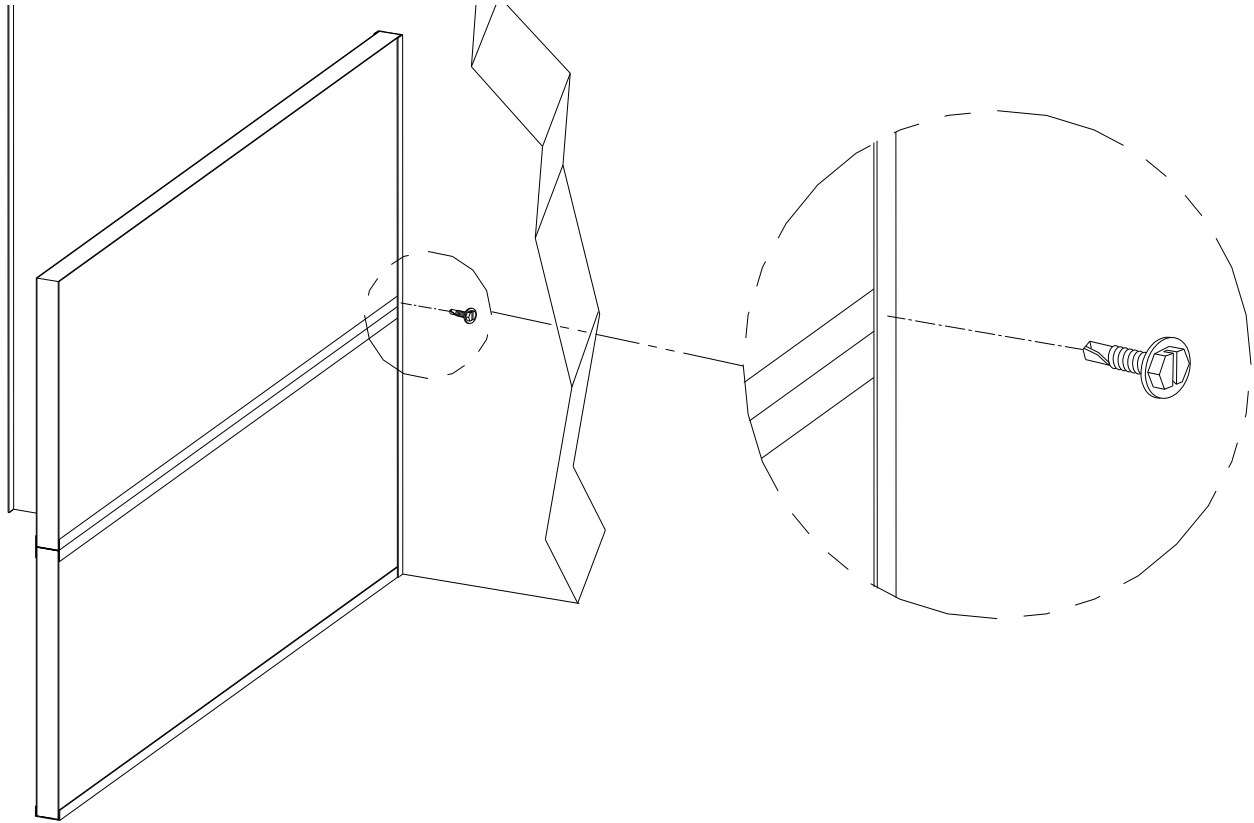

Figure 17

Section C

Front Wall Assembly

1. The front walls require different extrusions. Select the system you have from the list below and proceed to the appropriate section.
 - a. Systems ending at a building wall and are free standing at the other. Go to step 2.
 - b. Systems ending at a building wall at both ends. Go to step 2.
 - c. Systems that are free standing and do not connect to end walls. Go to step 4.
2. Position a “B” channel at the desired location according to your layout and secure to the wall with the supplied fasteners. See figure 18. Use a level to make sure the channel is vertical. Repeat for the opposite wall if your system end at a building wall at either end of the system. Skip to step 4.

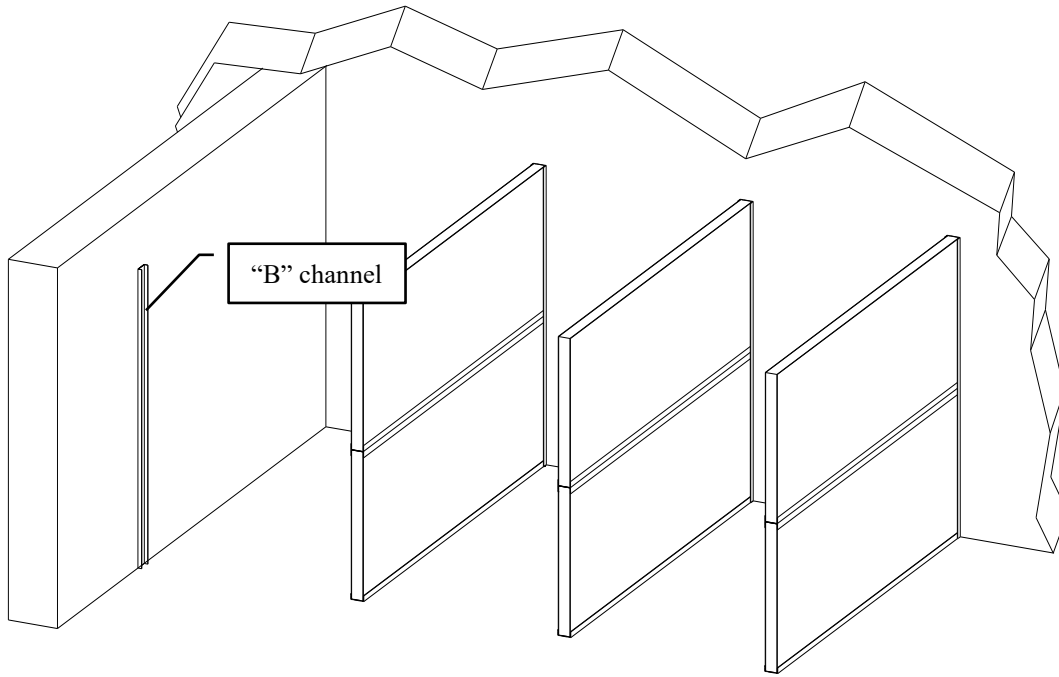

Figure 18

3. Systems that do not attach to end building walls use a “G” channel at each end wall. Place a “G” channel on to an end panel. See figure 19.

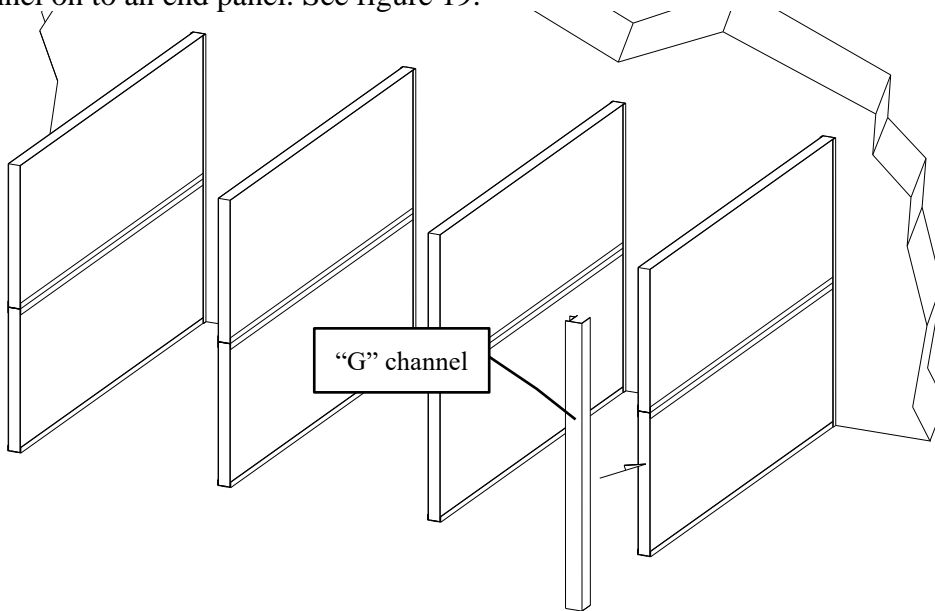

Figure 19

4. Beginning at an end of the system place the first “A” channel in place. This channel will overlap to the front as shown previously in figure 9. See figure 20.

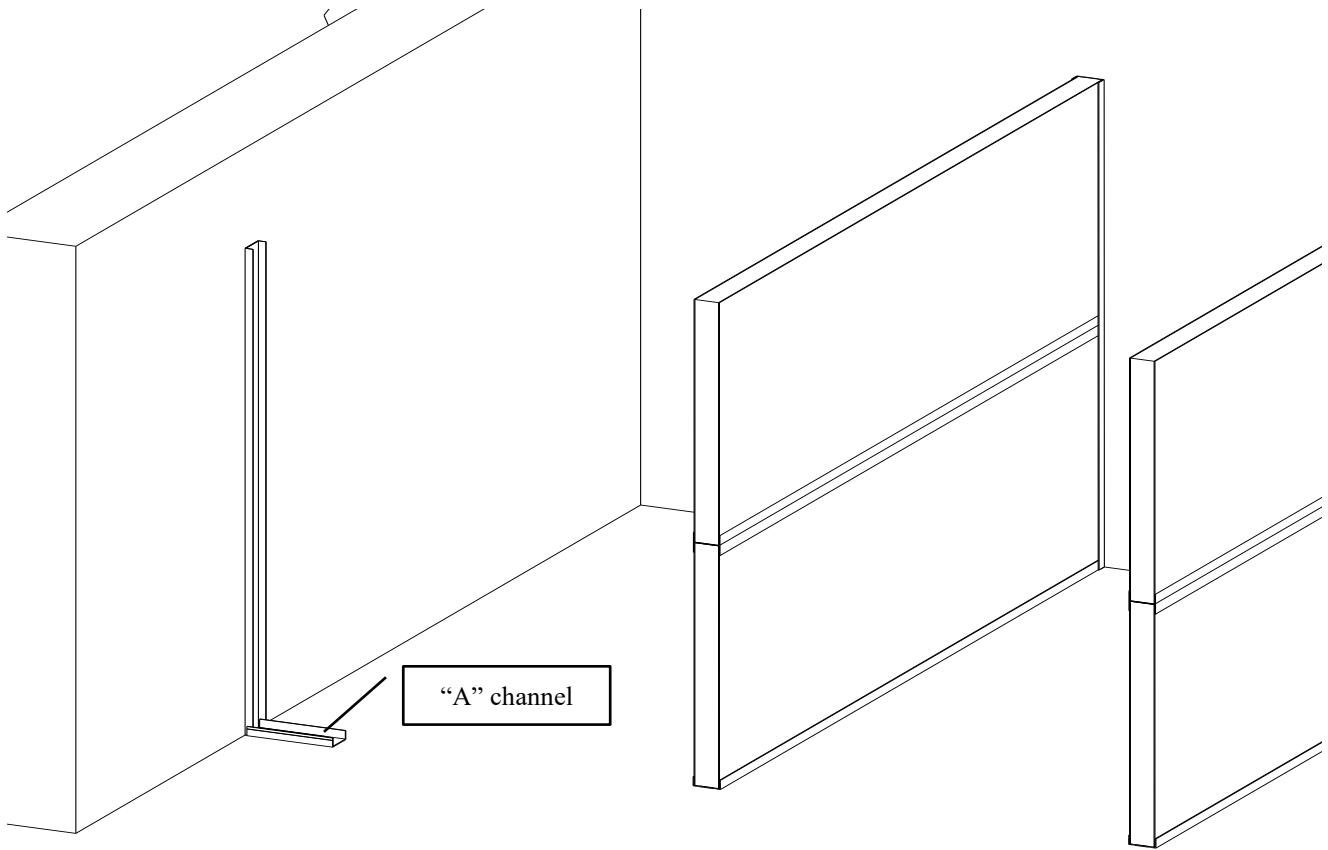

Figure 20

5. Insert the first filler panel in to the “B” and “A” channels or “G” and “A” channels depending on which system you have as covered in step 1 to 3 above. See figure 21.

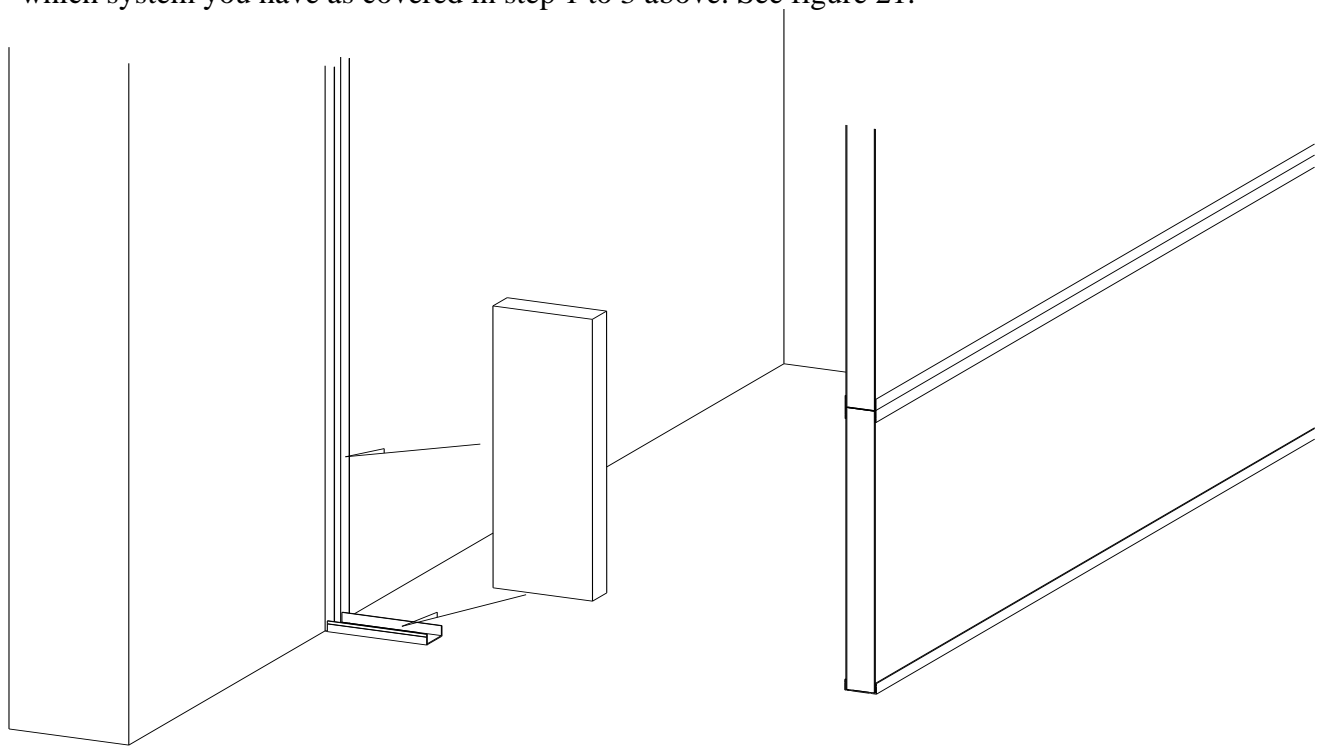

Figure 21

6. Place the next “A” channel on top of the filler panel from step 5. If this section of the front is a full height filler panel skip to step 9. See figure 22.

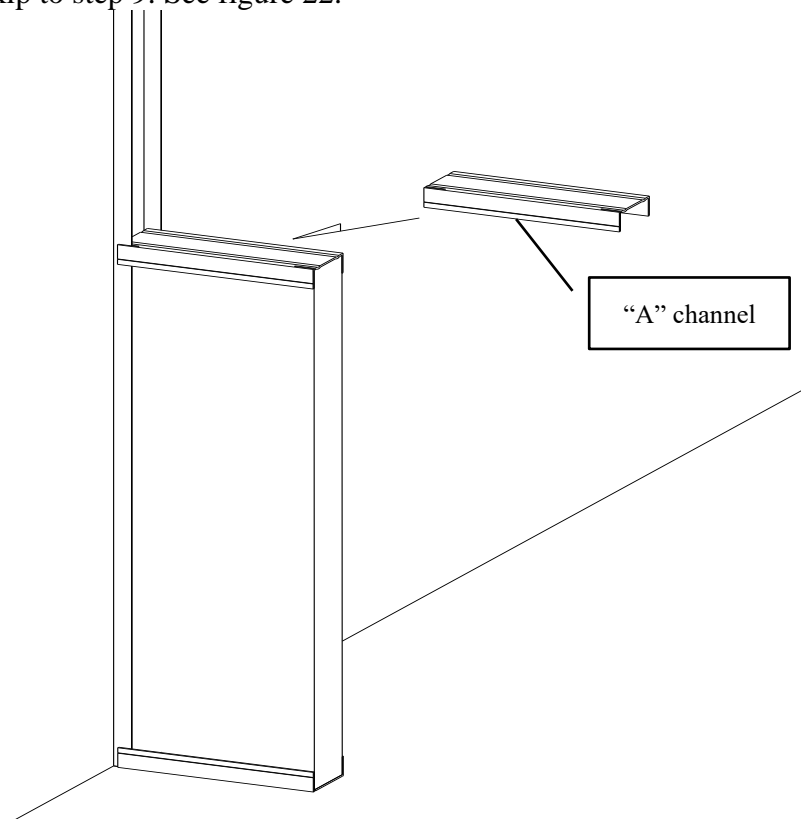

Figure 22

7. Place the window panel onto of the “A” channel from step 6. You must have a 2nd person to hold the window in place temporarily. See figure 23.

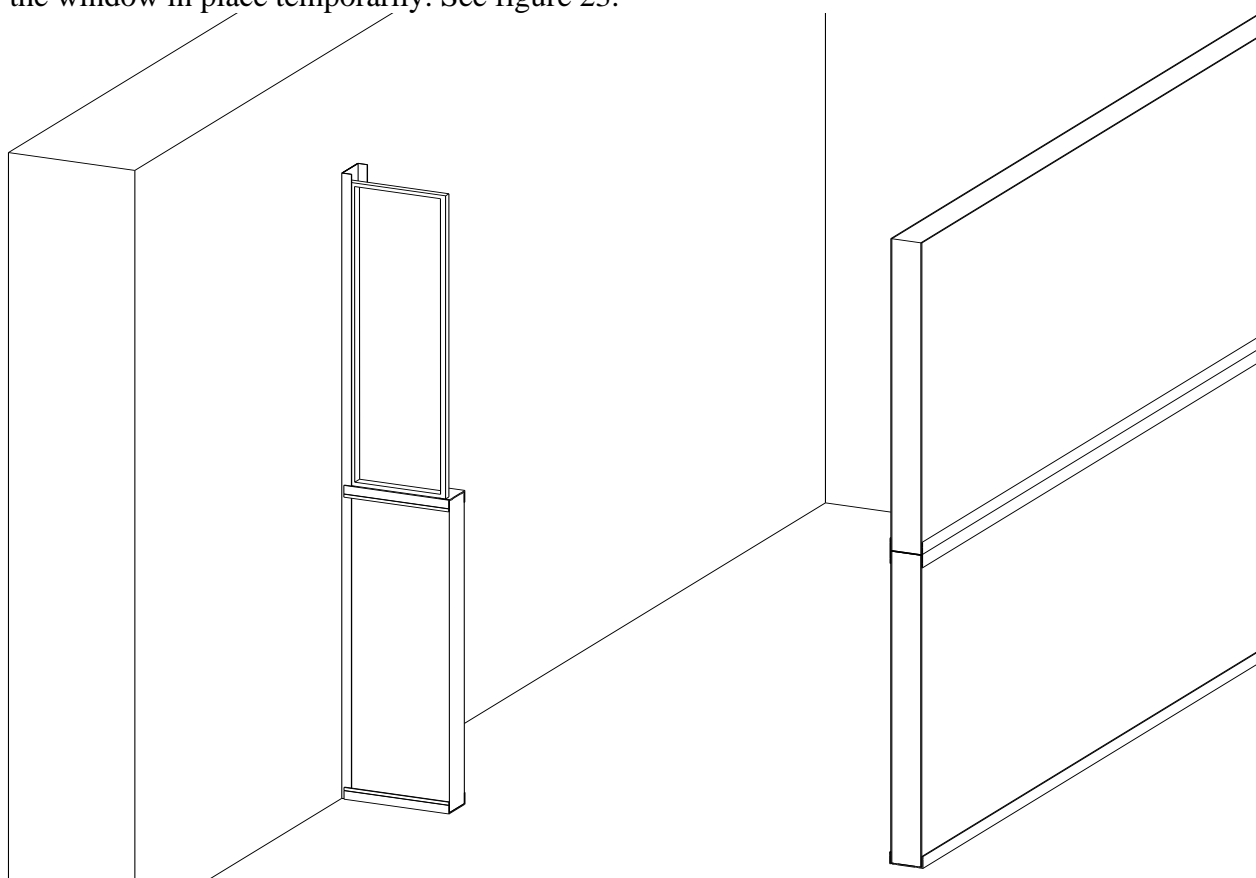

Figure 23

8. Place the first vertical “D” channel in place. See figure 24.

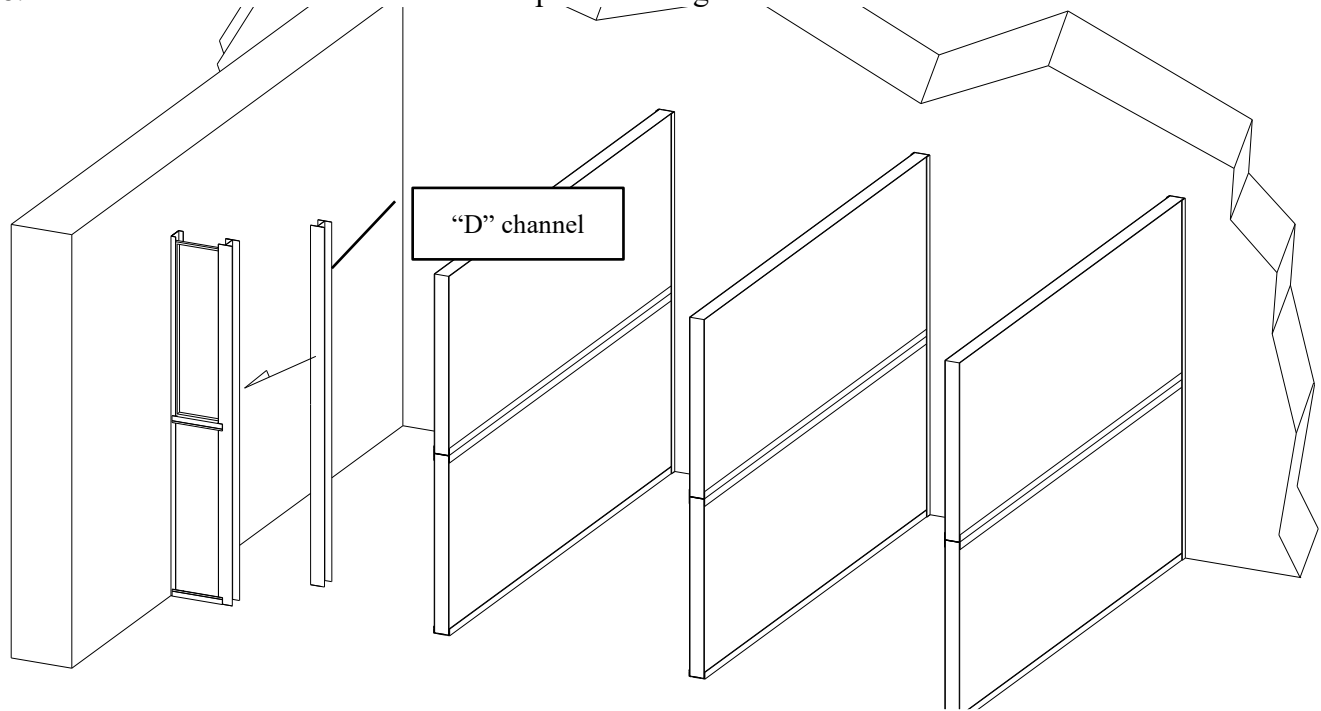

Figure 24

9. Install the door handle hardware. Note: door handles are not shown in the following drawings.
10. Place the first door unit into the “D” channel. The door is intended to open toward the aisle. Some layouts use both left and right handed doors. Consult your floor plans to make sure you have the correct door. See figure 25.

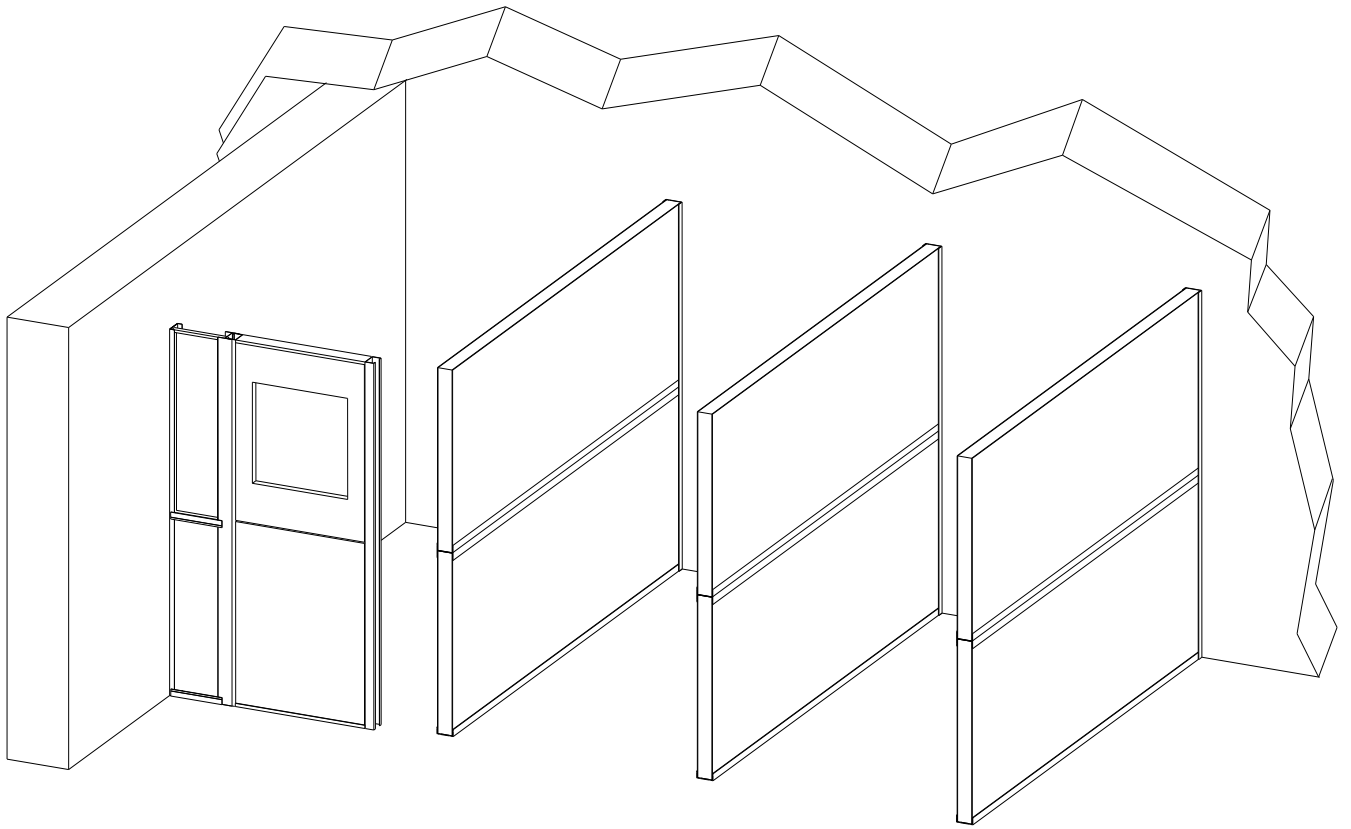

Figure 25

11. Place the next “D” channel onto the side of the door installed in step 9. See figure 26.

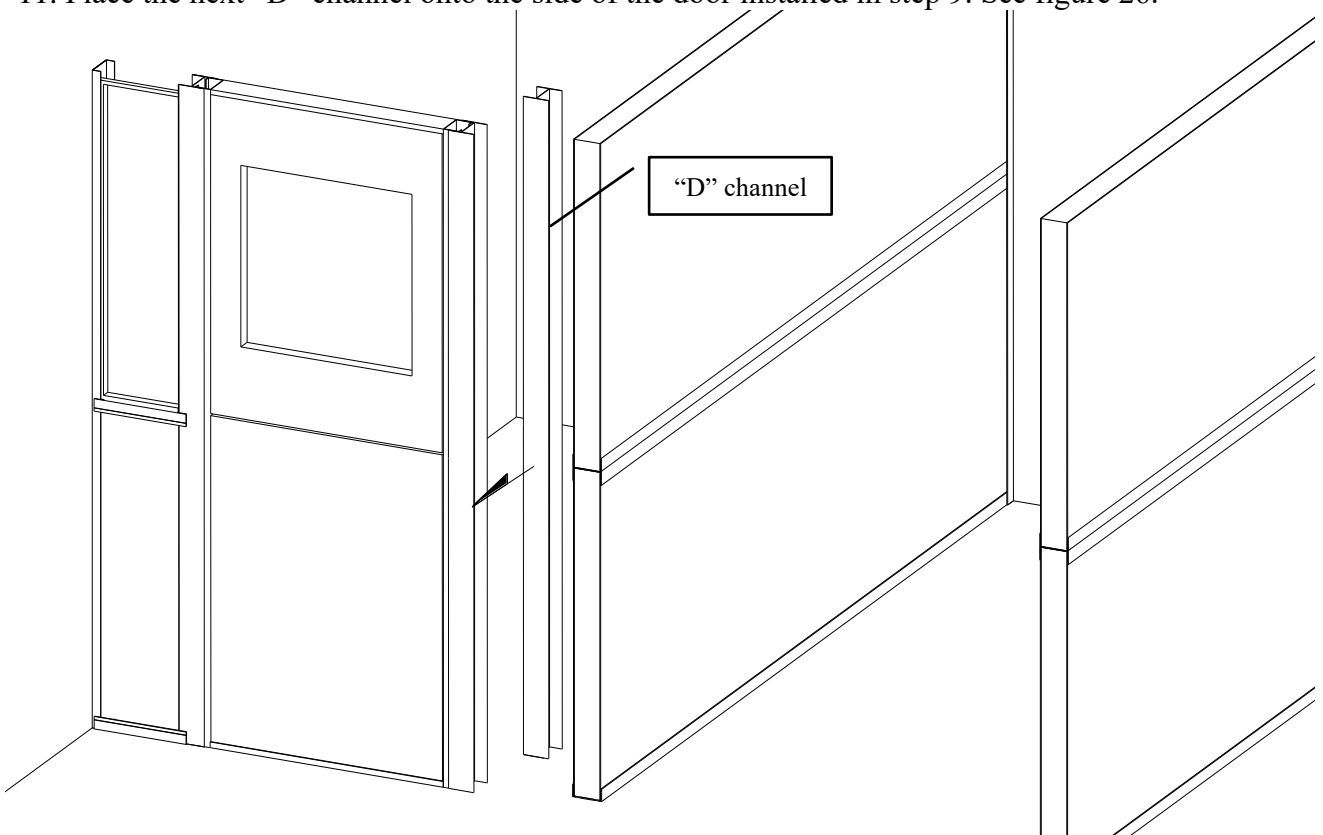

Figure 26

12. Place the next “A” channel onto the floor and slide into position on the previously installed “D” channel. See figure 27.

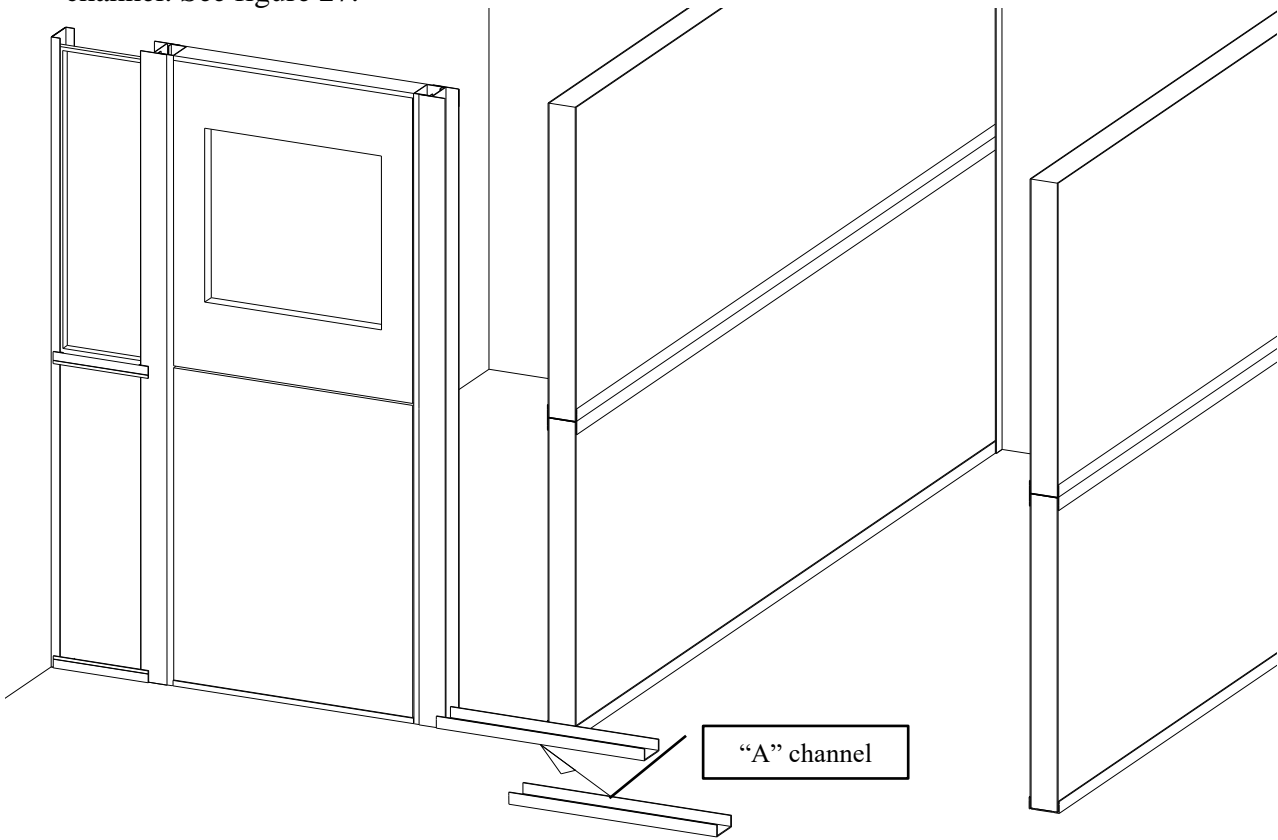

Figure 27

13. Insert a filler panel in to the “D” and “A” channels installed in steps 10 and 11. See your drawings for the correct panel. See figure 28.

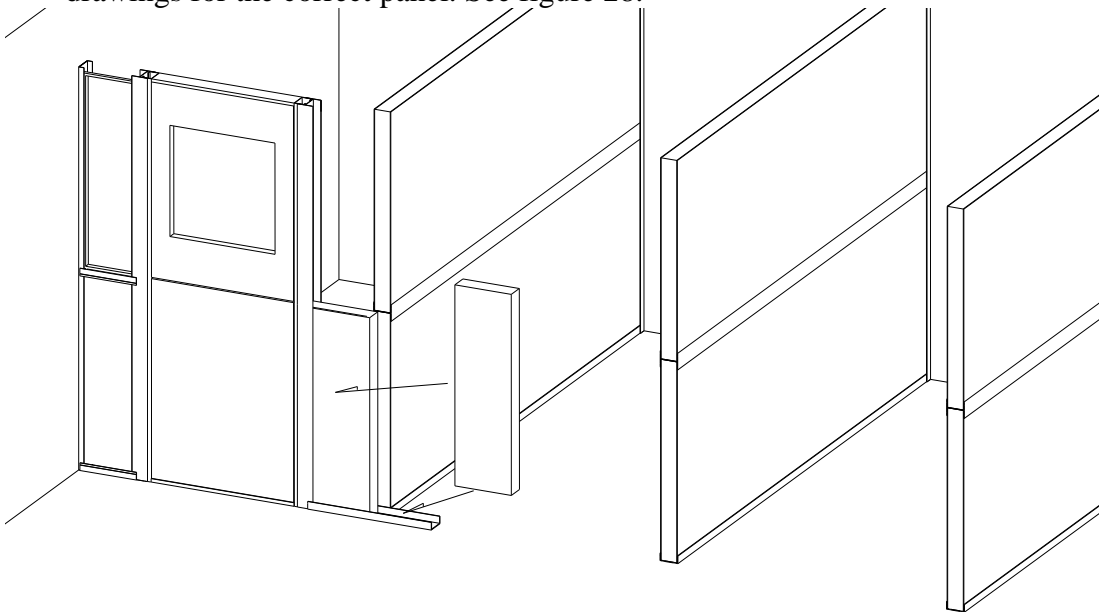

Figure 28

14. Place an “A” channel onto the filler panel you installed in step 13. Place the correct window onto the “A” channel and into the “D” channel. See figure 29.

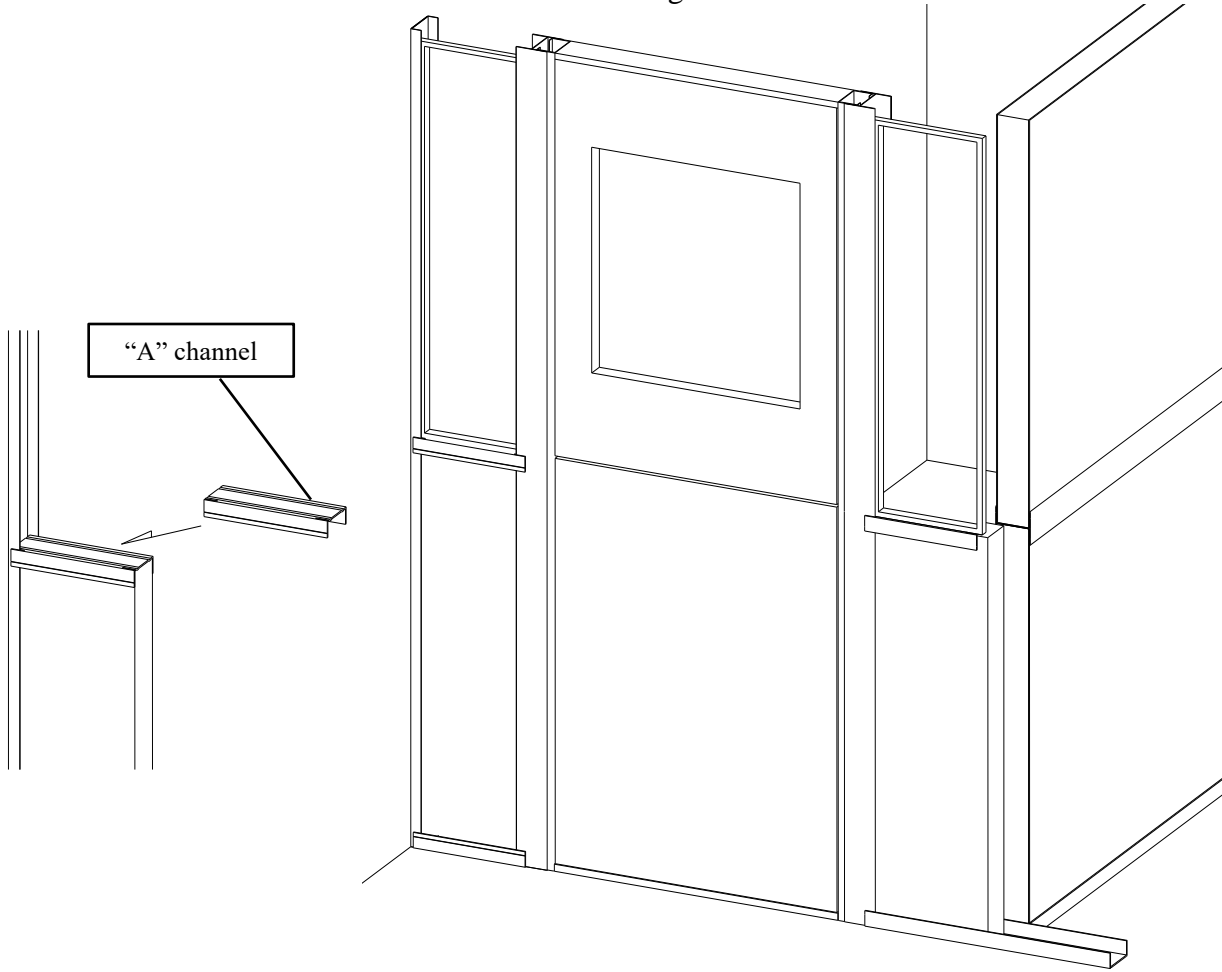

Figure 29

15. Place an “F” channel onto the previously installed “A” channel and also onto the front of the first division wall. This channel will also be fitted onto the previously installed filler panel and window. You may have to angle the “A” channel on the floor outward slightly to help insert this channel. See figure 30.

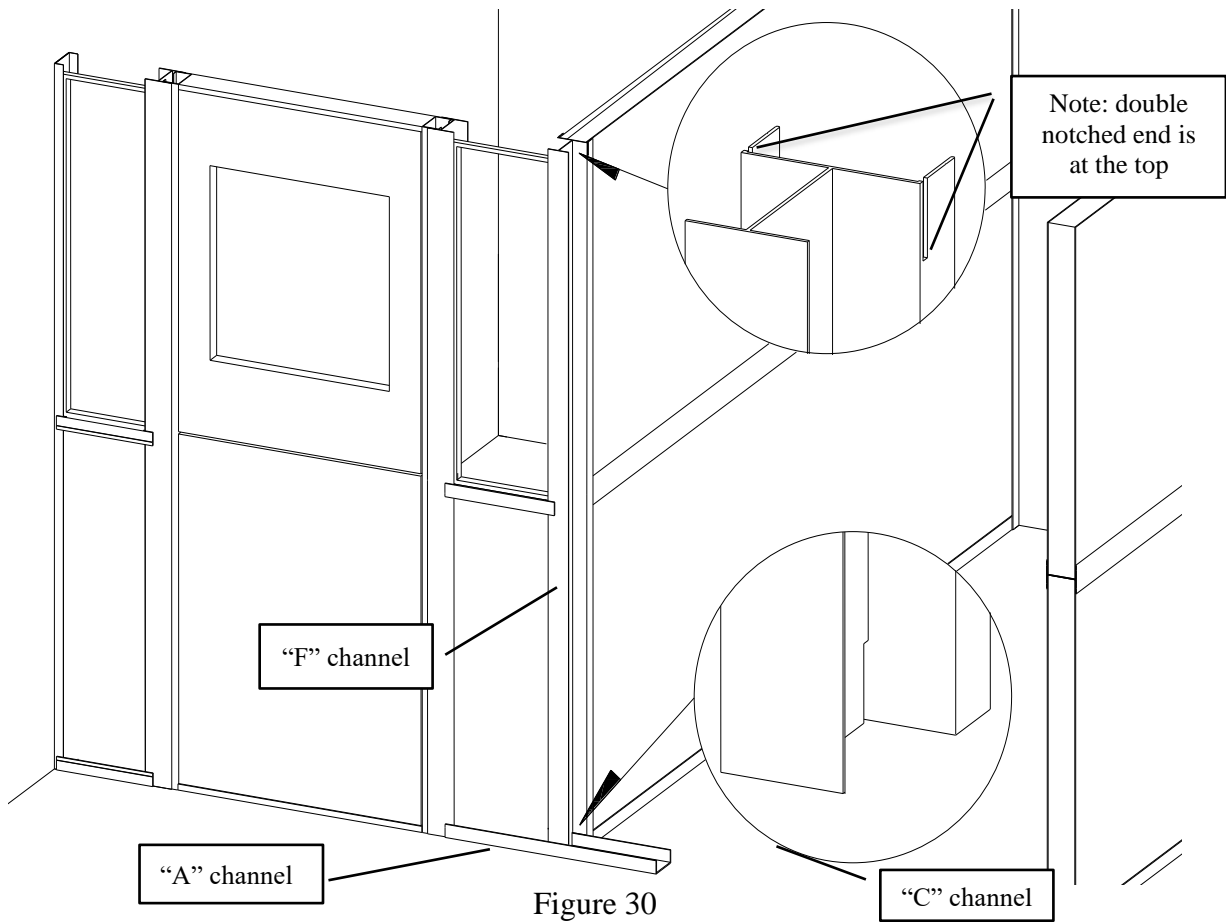

Figure 30

16. Place the “C” channel onto the top of the division panel. It should overlap the vertical extrusions on both sides. See figure 31.

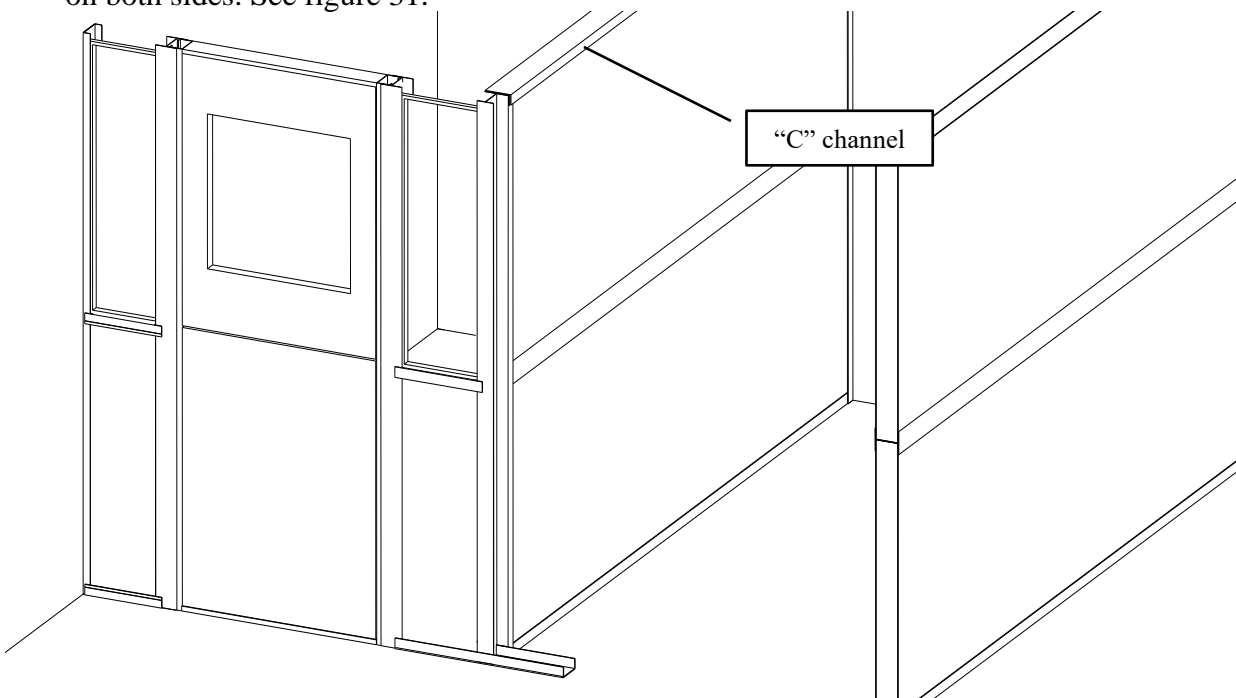

Figure 31

17. Using a level make sure the “F” channel is vertical, then using the supplied TEK screws fasten the “F” channel to the division wall extrusions. Make sure that the “C” channel does not cover

the notches at the tops of the “F” channels. Do this for both sides of the “F” channel. See figure 32.

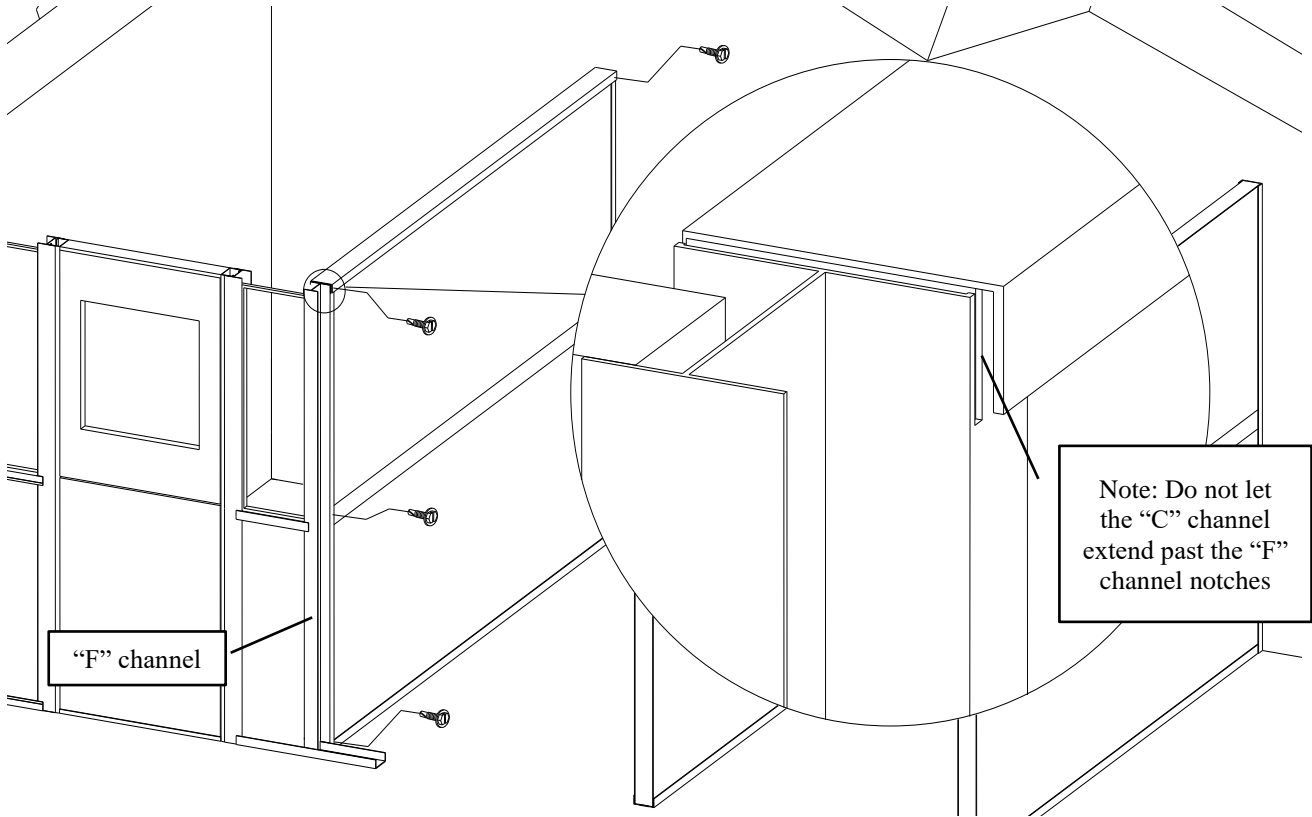

Figure 32

18. Measure to ensure that the division wall is in its correct position and that the “A” channel is centered left to right on the “F” channel. Secure with a TEK screw. See figure 33.

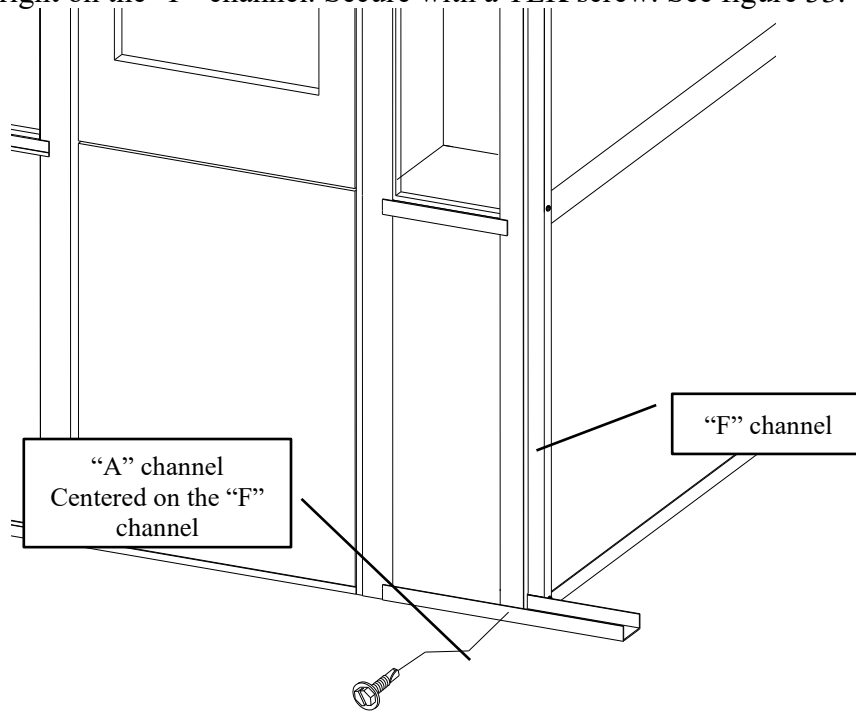

Figure 33

19. Using a level and a tape measure ensure that the “D” channels are vertical and that the door is centered between them. Note: there is clearance allowed for adjustment in your system. See figure 34 for the clearances. Use this as a guide to move extrusions to their correct positions before fastening.

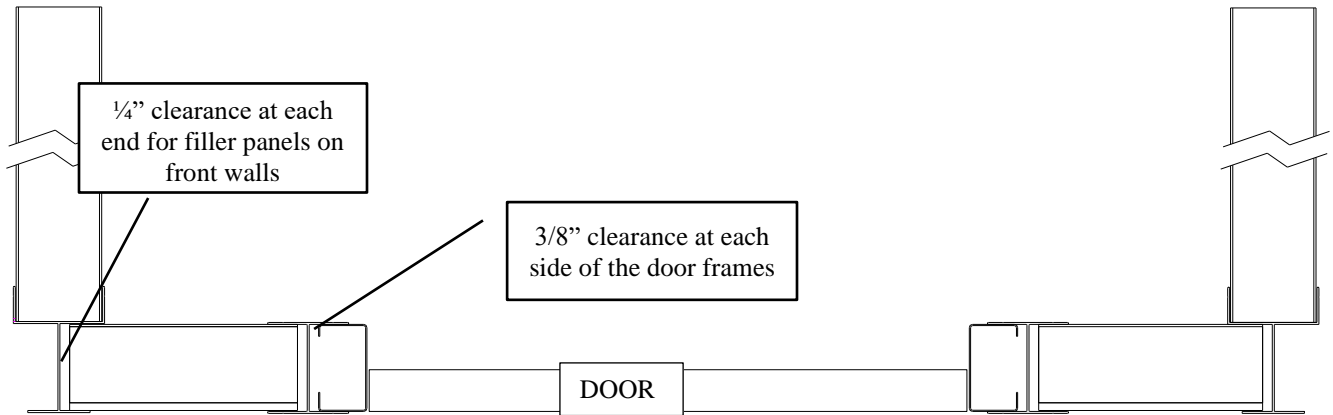

Figure 34

20. Measure to ensure that the horizontal “A” extrusions are in their correct positions. Begin fastening the bottom “A” channels to the vertical extrusions working from the bottom up. We suggest that you do this on the inside first then recheck that the “D” and “F” extrusions are still vertical. When you have ensured that the extrusions are vertical continue fastening the extrusions on the outside of the run. See figure 35.

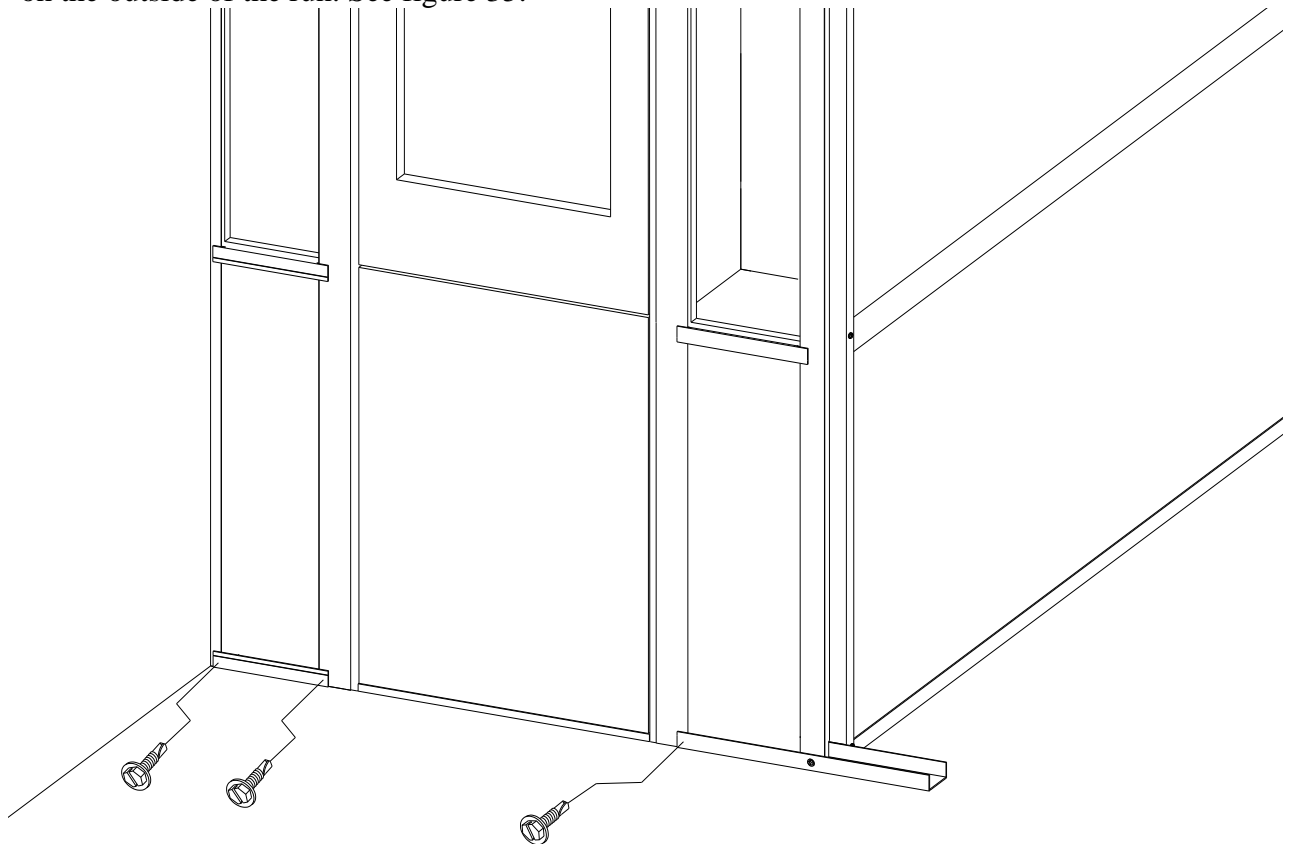

Figure 35

21. Begin fastening the mid-level “A” channels to the vertical channels. The “A” channels should be held level while doing this to ensure that the window sits flush on the channel with no gaps and that the window is vertical. See figure 36.

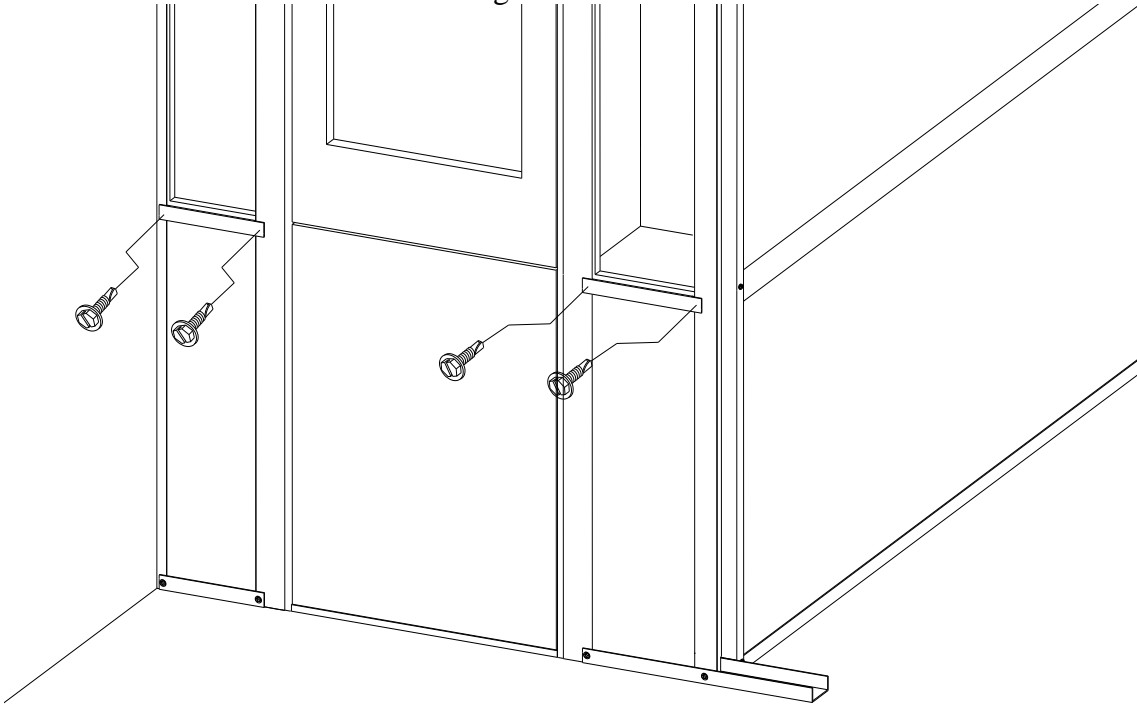

Figure 36

22. Using a level and a tape measure ensure that the door is vertical and roughly centered in the two “D” channels. When the door is properly in position the top and sides gaps should be even and not tapered. If they are not adjust the door until they are, this ensures that the door functions properly. Screw through the “D” channels into the door frame to secure it in position. Note: do not screw into the frame at the top of the “D” channels, this will interfere with the top cap. See figure 37.

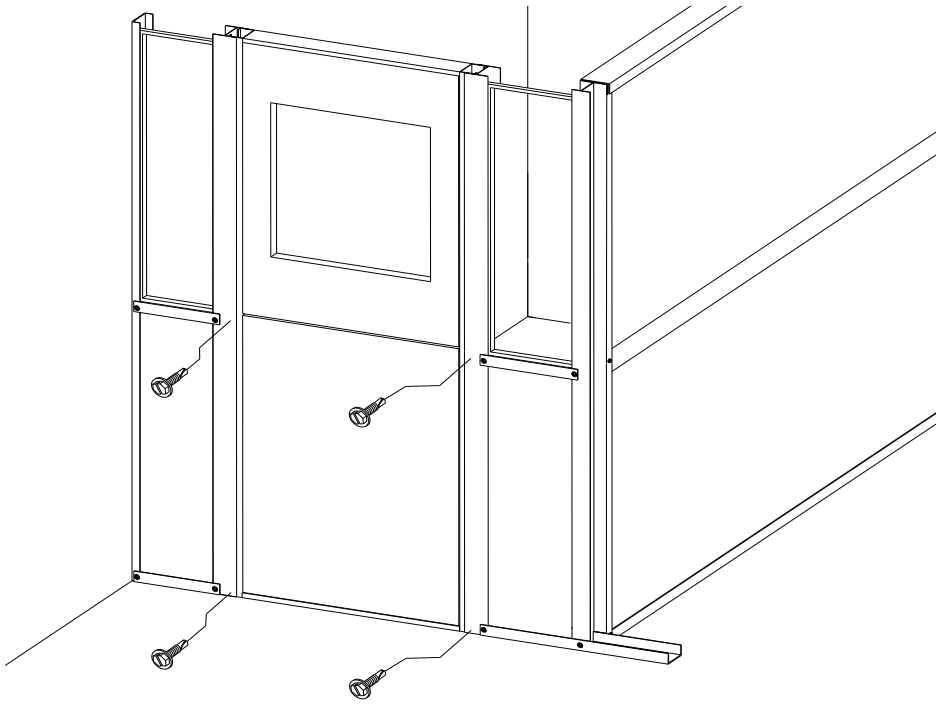

Figure 37

23. Place the appropriate “C” channel onto the top of the front wall. The rear flange should fit over “B” channels and fit into the notches at the top of the “F” channels. Secure as shown in figure 38. Note: the “C” channel must be raised slightly and leveled before fastening. Make sure that the bottom edges of the channel do not interfere with the opening of the door at the top. It is designed to allow some adjustment for level in the system. Secure “C channel to the vertical extrusions using the supplied offset plates as shown. Do not use the offset plates on the end where the system attaches to walls.

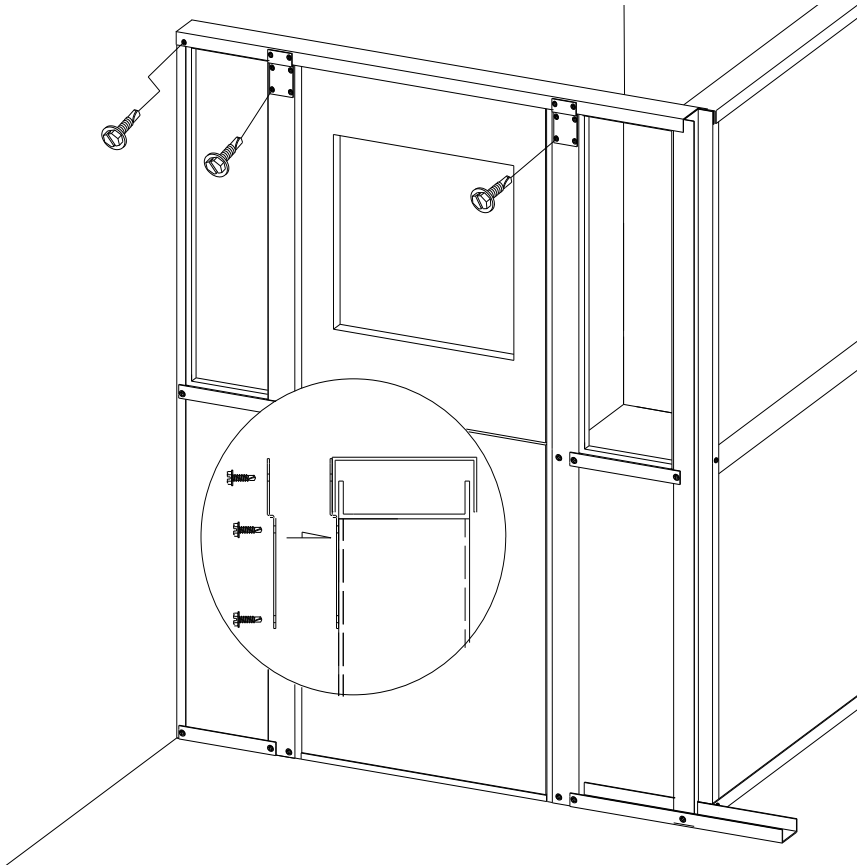

Figure 38

24. Center the window panels left to right and install the EZ Verticals on either side of the windows. They should be placed on the inside of the run. Note the orientation of the flexible seal along one edge of the EZ Vertical. See figure 39.

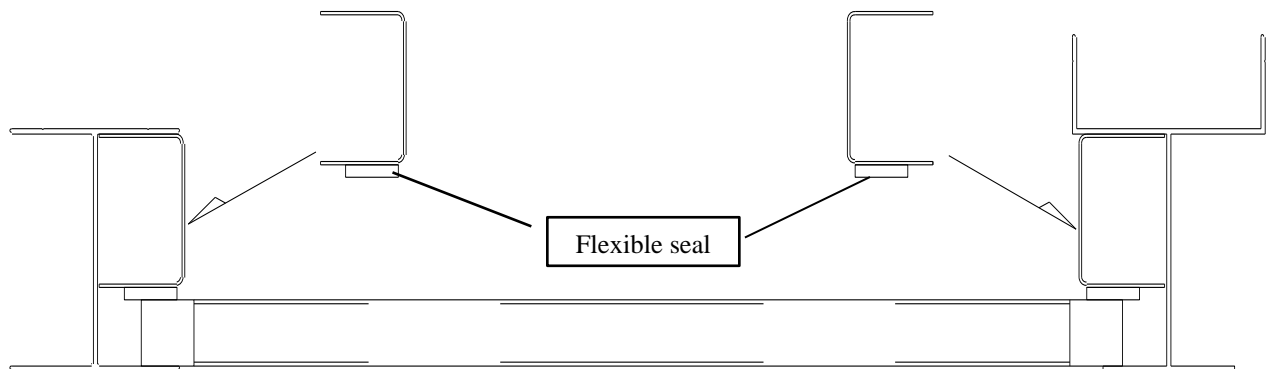

Figure 39

25. Using the above procedures begin assembling the rest of the system one run at a time.
 26. Systems ending on a side wall require securing an “A” channel to the wall before the filler panel and glass window on that side of the door are installed. The door and the filler panels and the two horizontal “A” channels can be angled outward to allow the parts to fit into the proper extrusions. See figure 40.

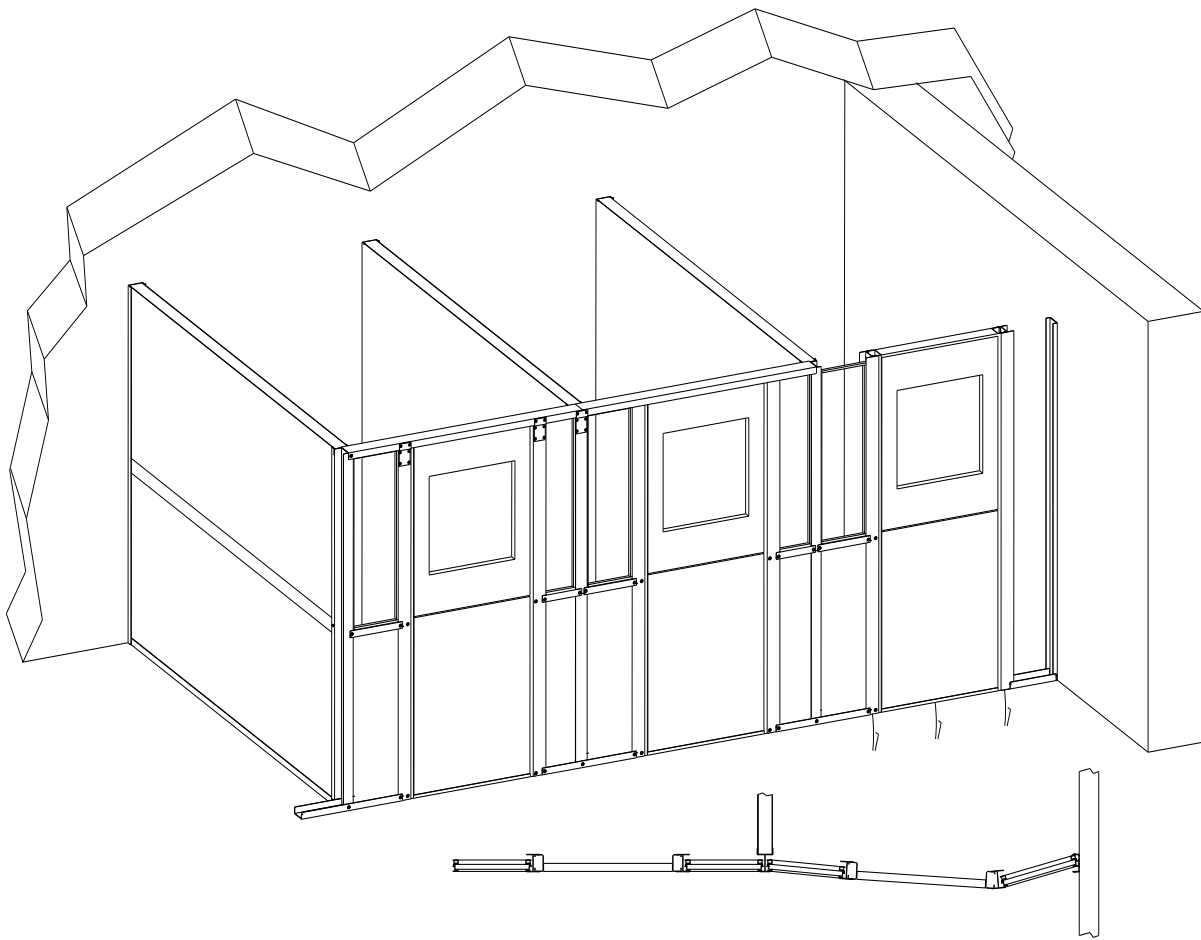

Figure 40

Section G Sealing

1. Clean along the edges of the extrusion where they come in contact with the concrete and the panel materials.
2. Apply a thin bead of the provided sealant along the seams where the extrusions come in contact with the concrete and the panel materials.
3. It is not necessary to seal the “C” top cap extrusions.

Maintenance

Over time, your Mason kennels might require adjustments, lubrication, or replacement parts in order to remain in top working condition. We recommend a yearly maintenance schedule to lubricate door

hinges and any other moving parts. If your kennels should need any replacement parts, our professional sales engineers will be happy to review your original order and assist you.

Note: Wall mounting hardware is shown only for reference purposes and is not included

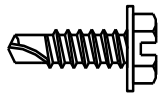

ID# - 5290

#10 X.625" TEK HEX WASHER HEAD SST
SELF TAPPING SCREW

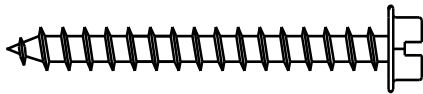

ID# 1368

#12 X 2" HEX HEAD SCREW



ID# - 3808

1/4" x 1 3/4" TAPCON